

---

# **CSU's Multi-GNSS at Jicamarca**

**Jade Morton**

**Department of Electrical and Computer Engineering  
Colorado State University**

# Multi-GNSS Event-Driven Data Collection System

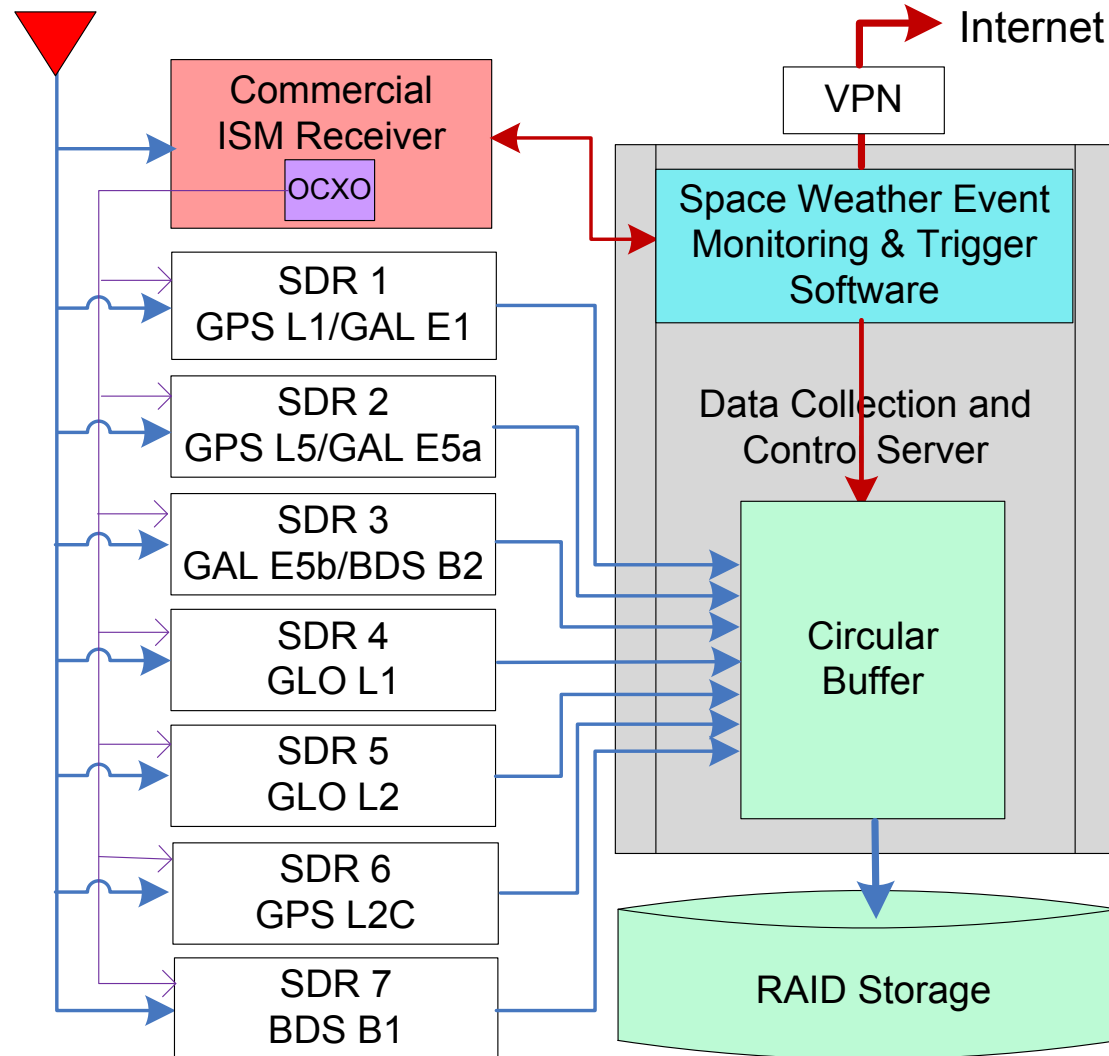

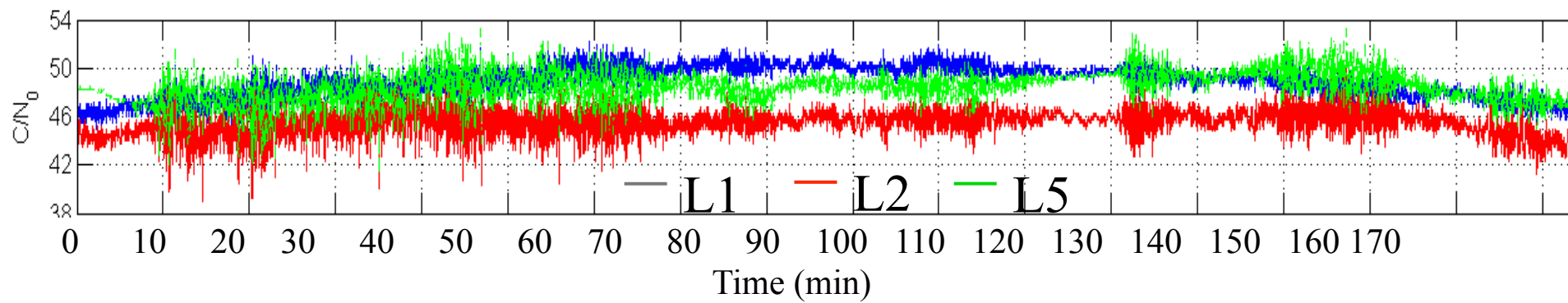

Jicamarca, Peru

3/11/2013, 13:30 UTC

# Amplitude Scintillation: S<sub>4</sub> Index

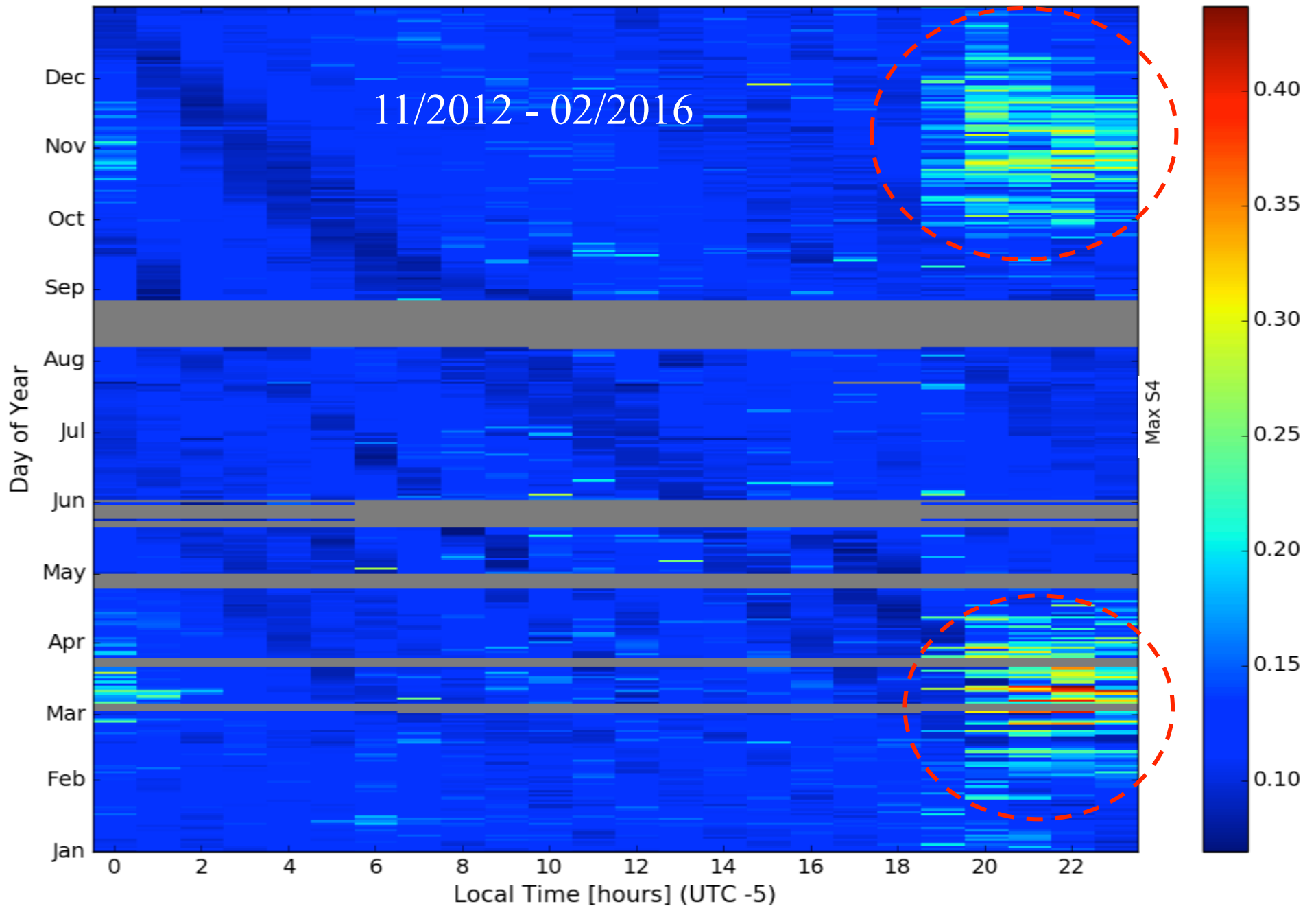

# Phase Scintillation Index: $\sigma_\phi$

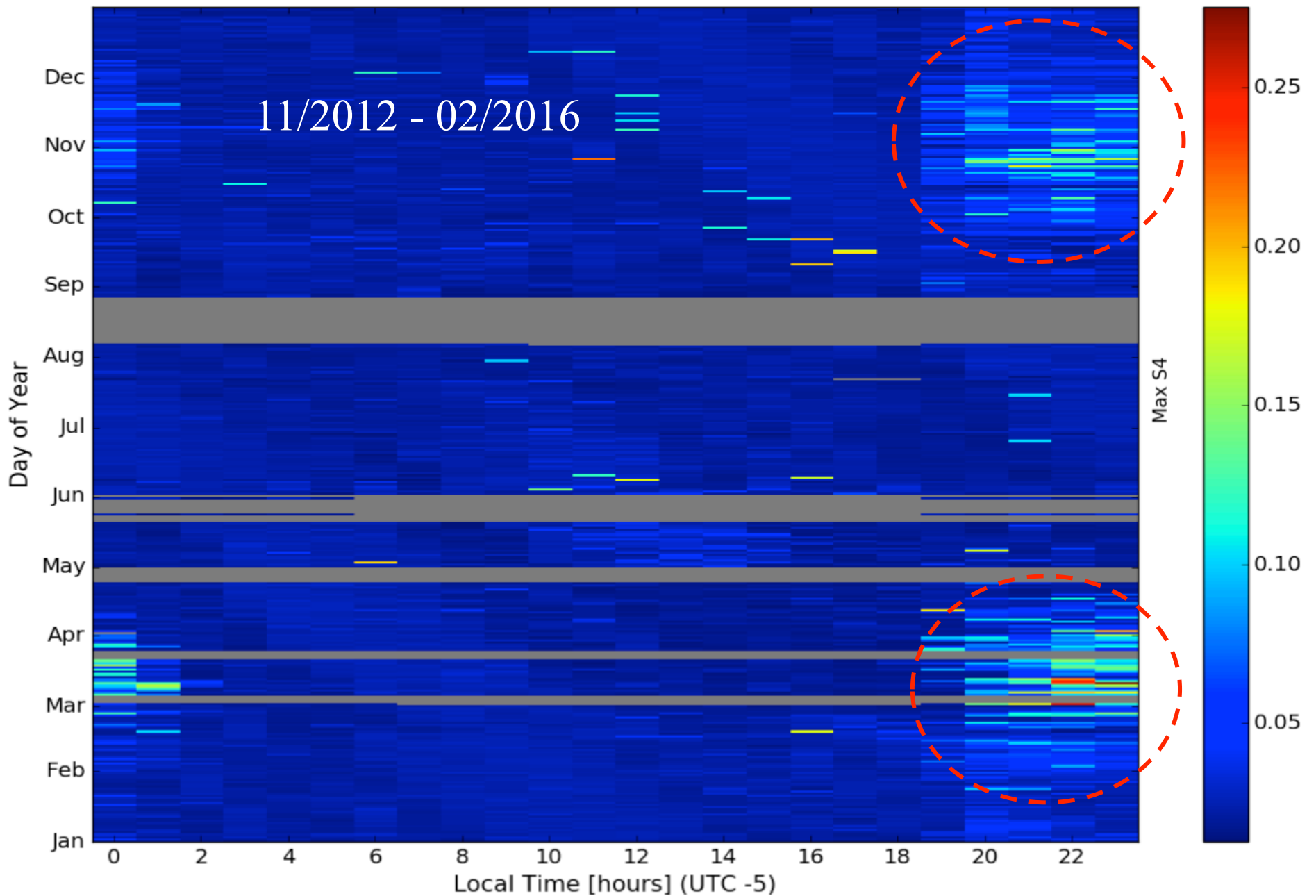

# Scintillation Intensity Probability Distributions

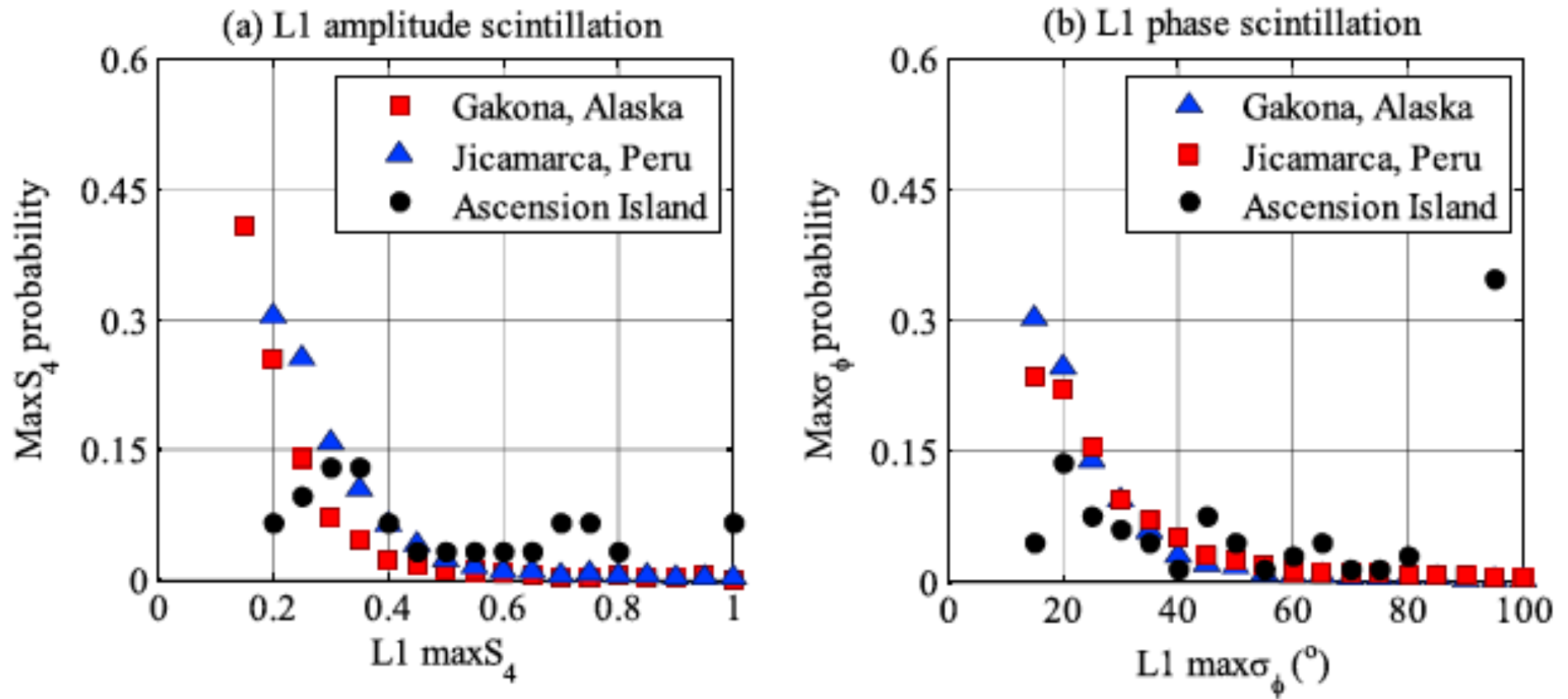

# Scintillation Duration Probability Distributions

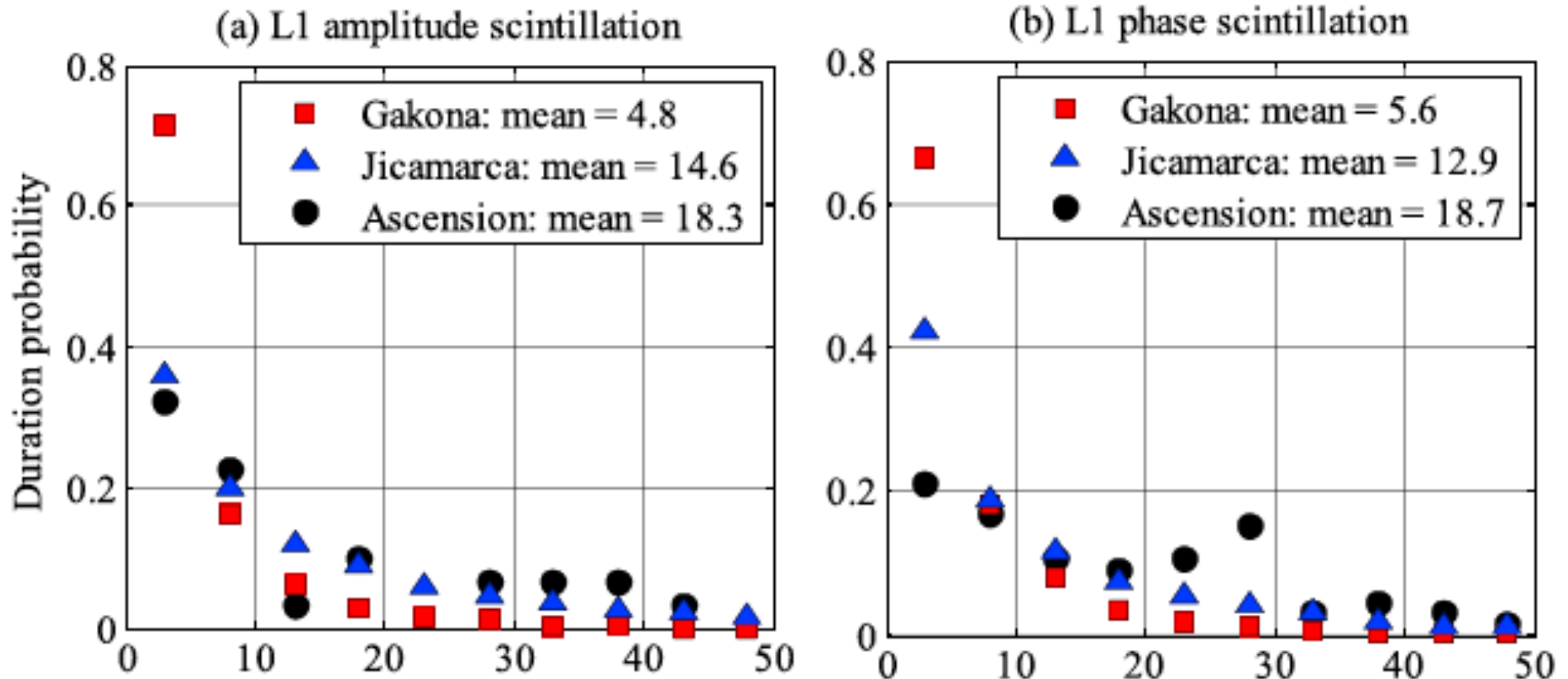

# Diurnal Patterns

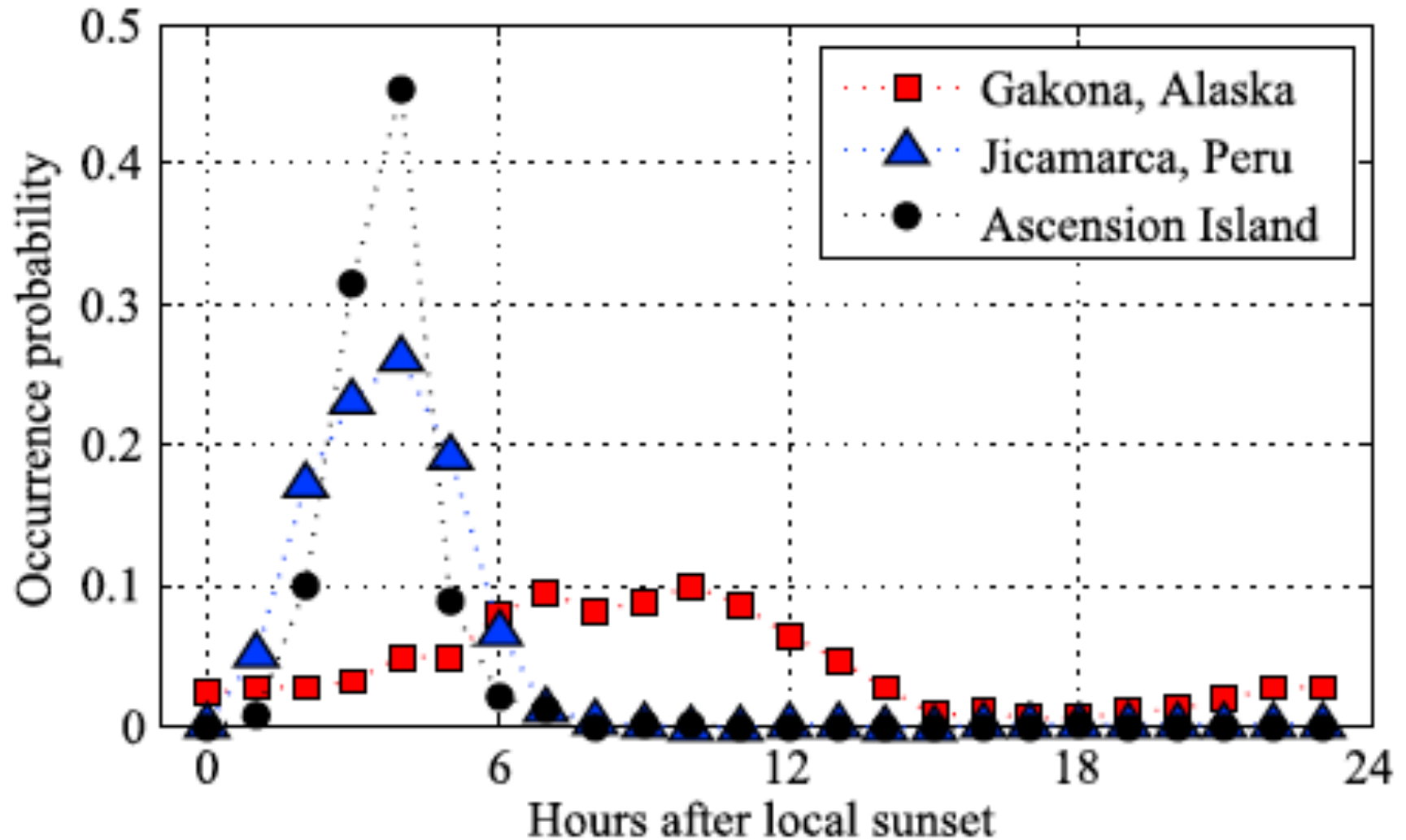



# Seasonal Variation + Solar Activities

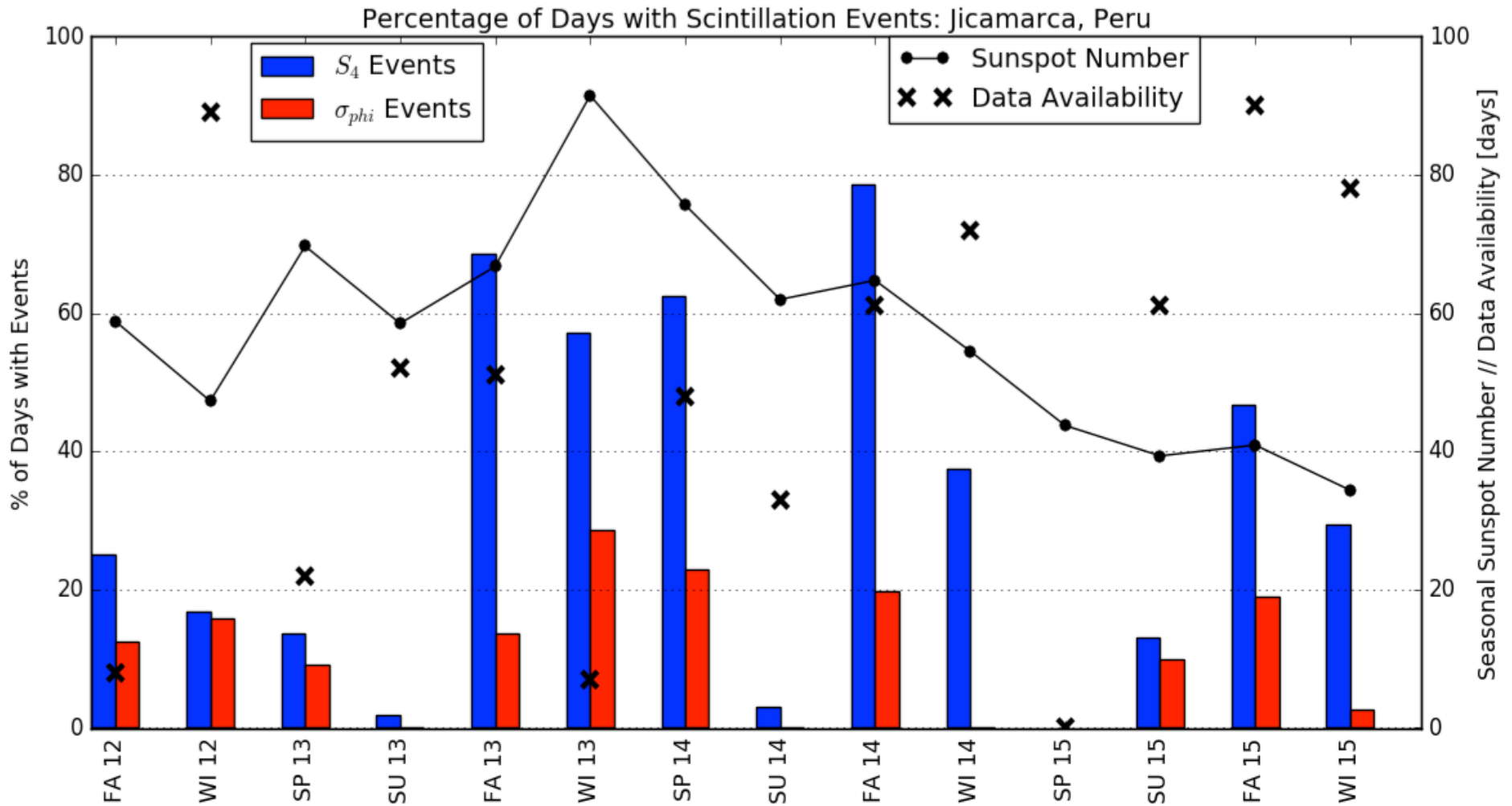

# TEC & TEC Spatial Gradients

