

**2001 CEDAR-SCOSTEP**

Longmont, Colorado

June 17-22, 2001

Tutorial Lecture #2

by Karin Labitzke

Free University of Berlin, Germany

Influence of the 11-Year Solar Variation  
on Atmospheric Circulation

# **Influence of the 11-Year Solar Variation on Atmospheric Circulation**

**K. Labitzke**

**Institut für Meteorologie, Freie Universität Berlin**



## **1000 Years of Climate Change**

**...We are living in unusual times. 20th century climate was dominated by near universal warming. Almost all parts of the globe had temperatures at the end of the 20th century that were significantly higher than when it began.**

**...How unusual was the last century when placed in the longer-term context of climate in the centuries and millennia leading up to the 20th century?**

**(quoted from Raymond S. Bradley, IGBP Newsletter 44, December 2000)**



**...A wide variety of annually resolved paleoclimate proxies are available to answer this question. These include: historical documentary records, tree rings, ice cores, varved lake sediments, etc.,**

**...**

**Studies of these and other proxies reveal that temperatures declined from A.D.1000 until the late 19th century, followed by warming at a rate that is unprecedented in the record, leading to temperatures in the late 20th century that were unique in the context of the entire millennium. Statistical studies and energy balance models indicate that much of the variability of temperature over the millennium can be accounted for by variations in the output of energy from the Sun, explosive volcanic eruptions and internal variability of the ocean–atmosphere system.**

**The 20th century warming is inexplicable by these mechanisms. Only increased levels of greenhouse gases appear to explain the unusual warming...**

**(quoted from Raymond S. Bradley, IGBP Newslet-**

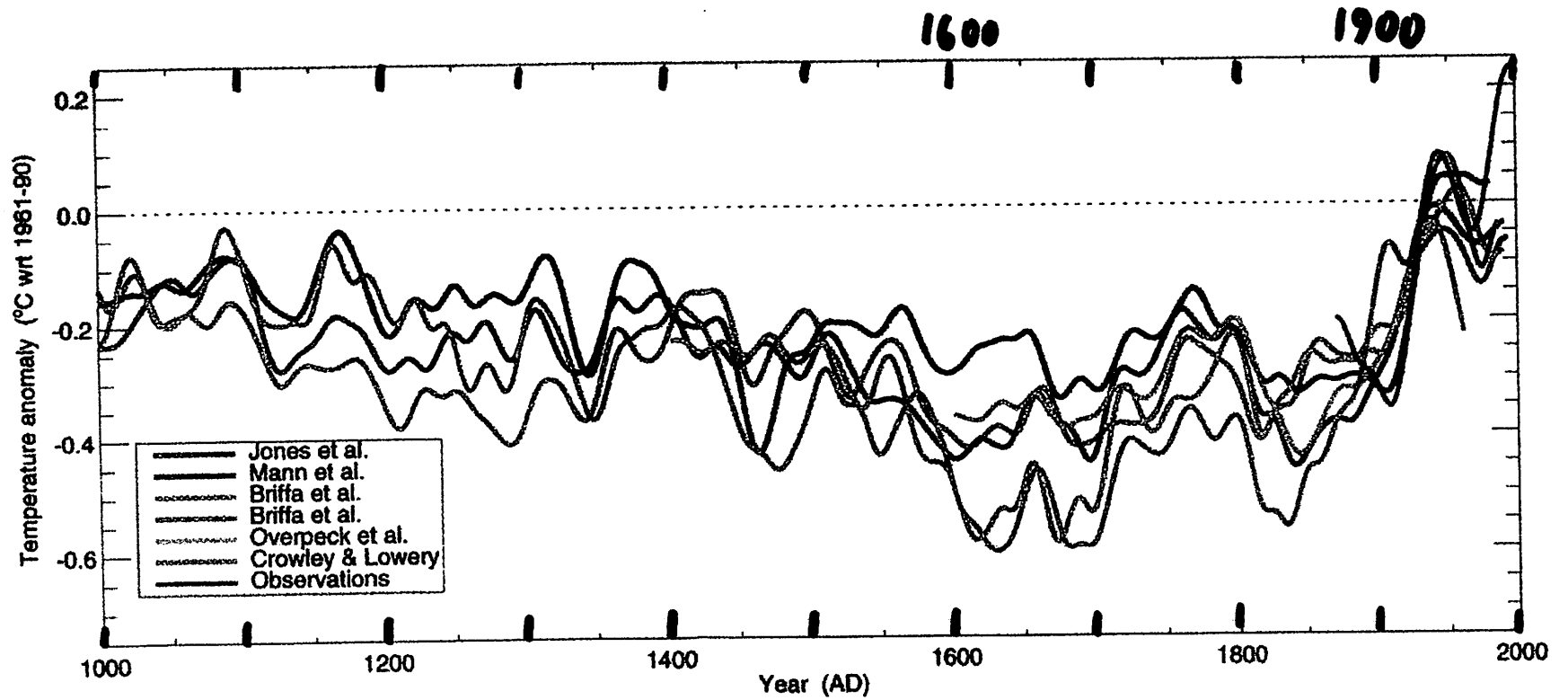
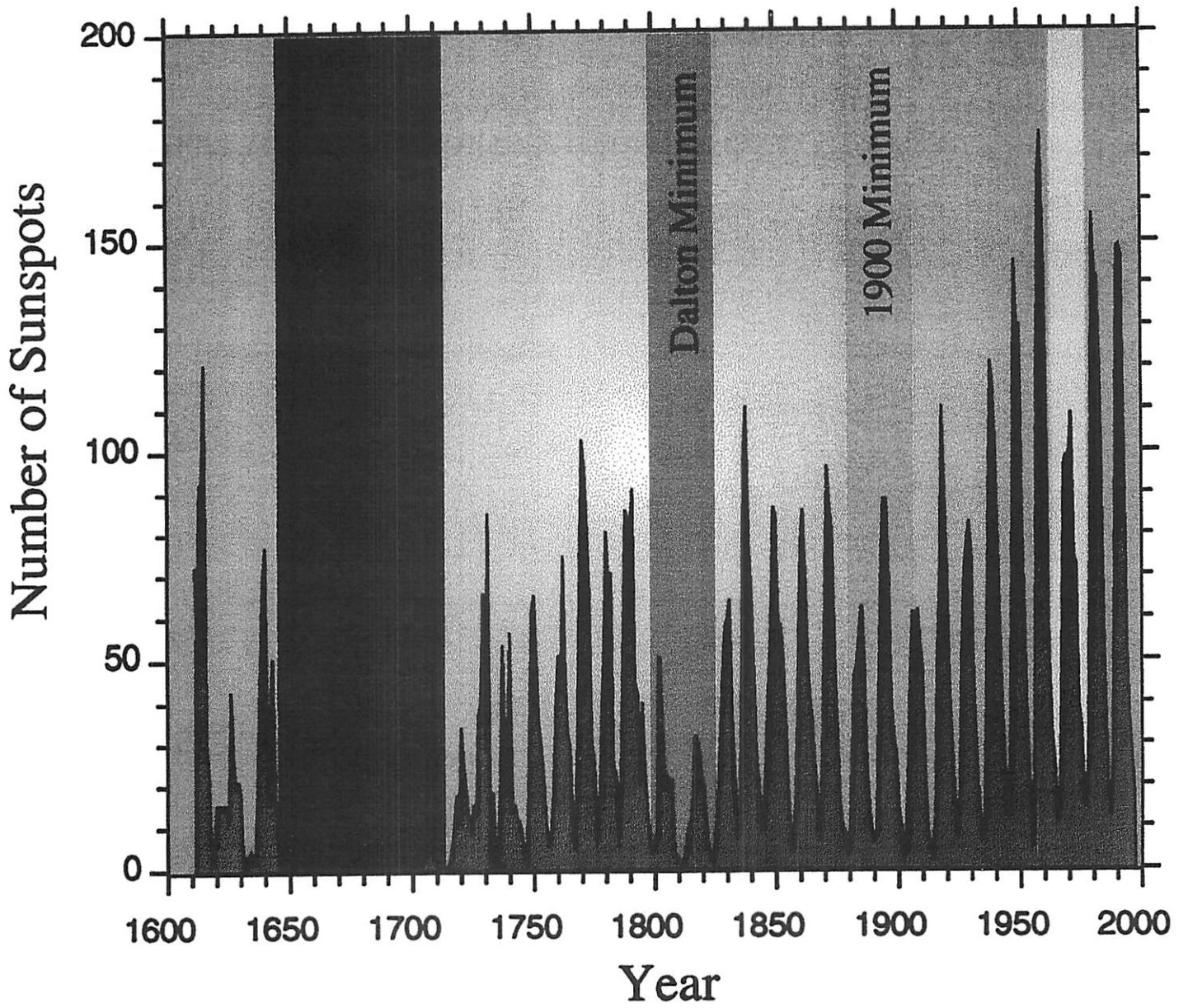
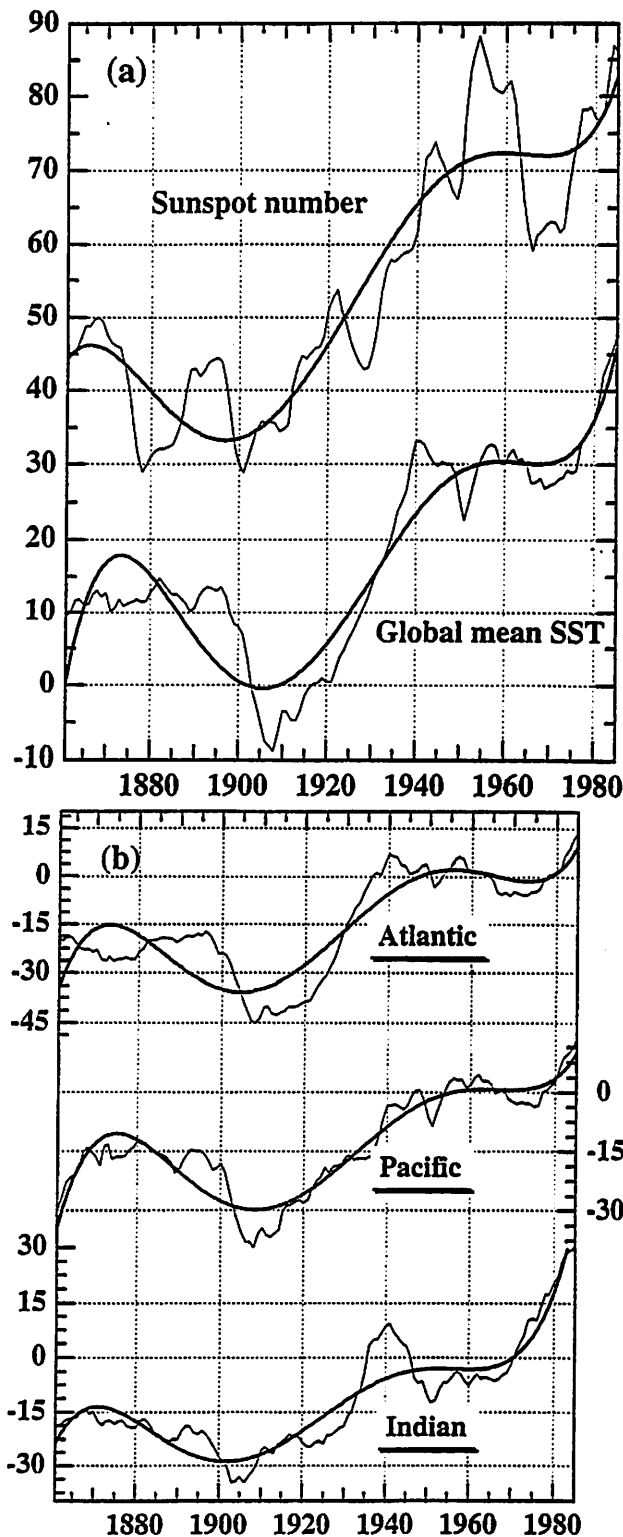

Figure 1. Various estimates of large-scale (northern hemisphere) temperature variations over the last millennium reference to the average from 1961-90. The differences relate, in part, to the fact that they do not all repr the same season, or geographical domain (from Briffa et al., 2000. J. Geophys. Res., in press).

# Sunspot Record





G. Reid, 2000

Figure 1. (a) Eleven-year running mean of the annual sunspot numbers (upper light curve) and of the annual mean global sea-surface temperature shown as departures from the 1951-80 average in units of 0.01K (lower light curve). Heavy curves are least-squares 7th degree polynomial fits to the data. (b) Same as (a) for the three major ocean basins.

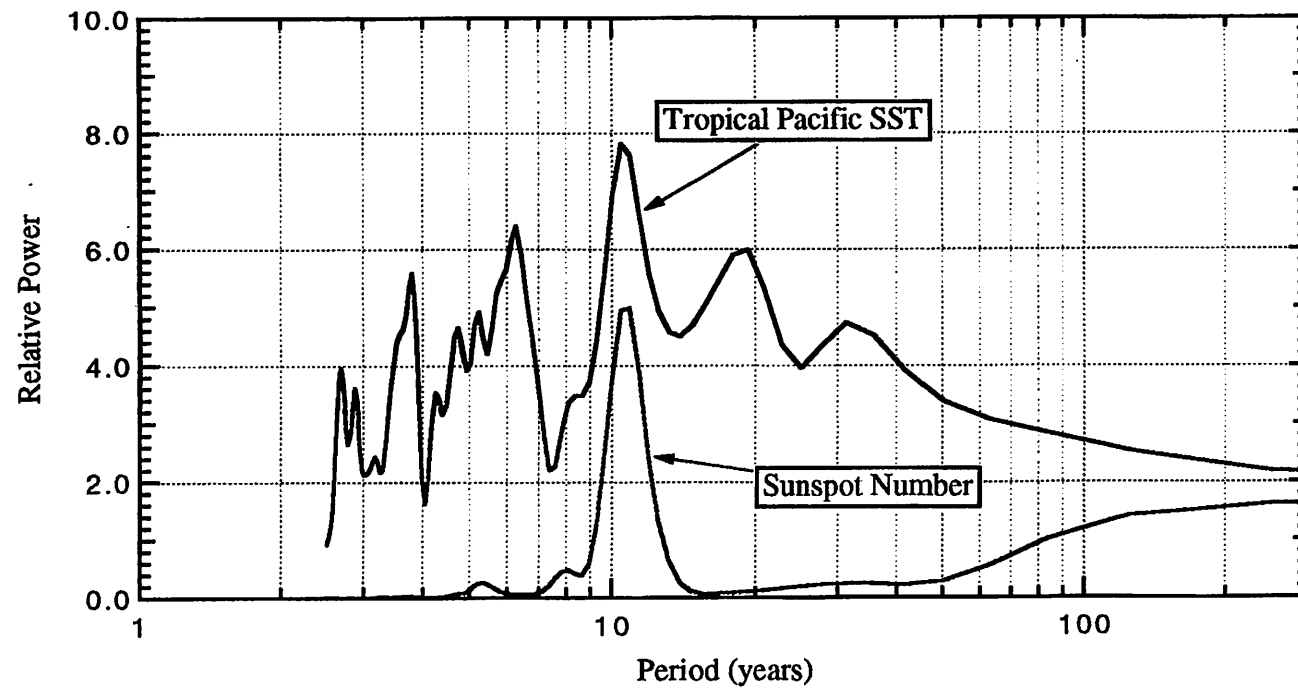
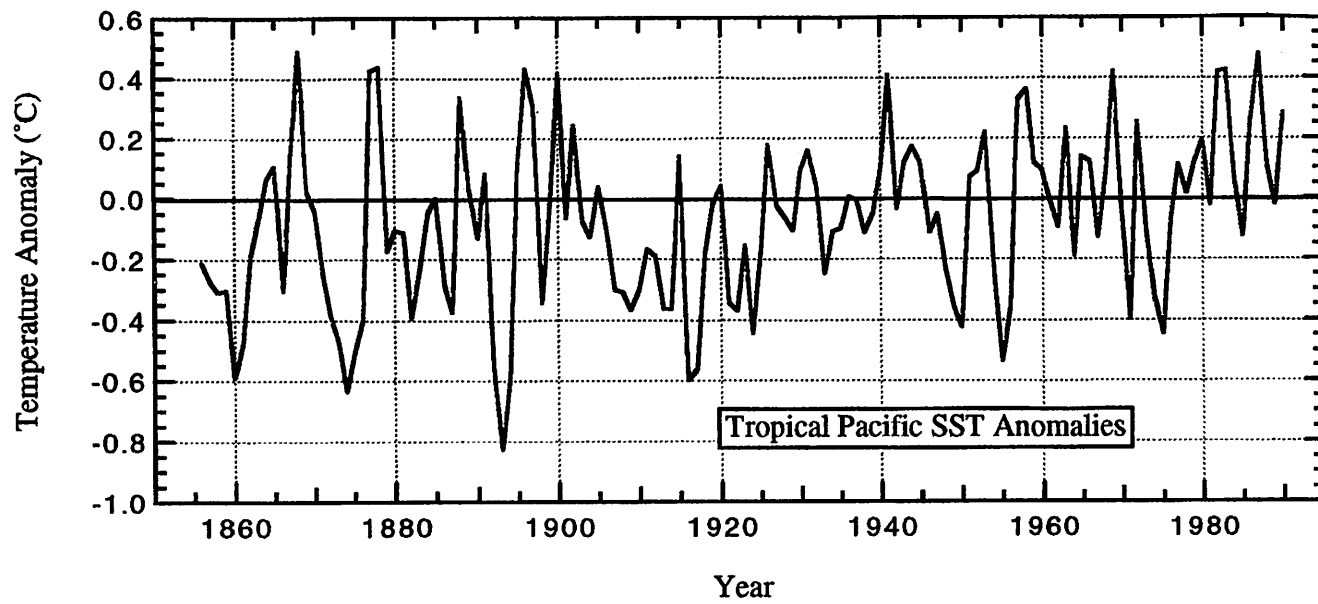



# Solar Activity and Temperature During 400 Years

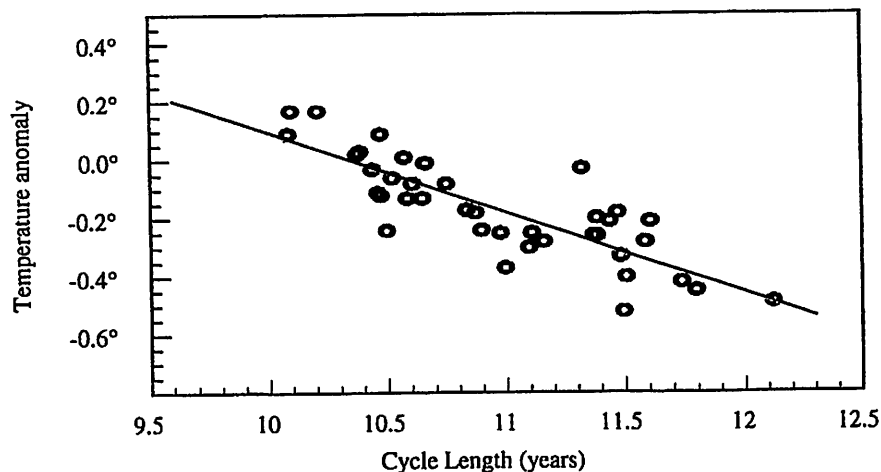
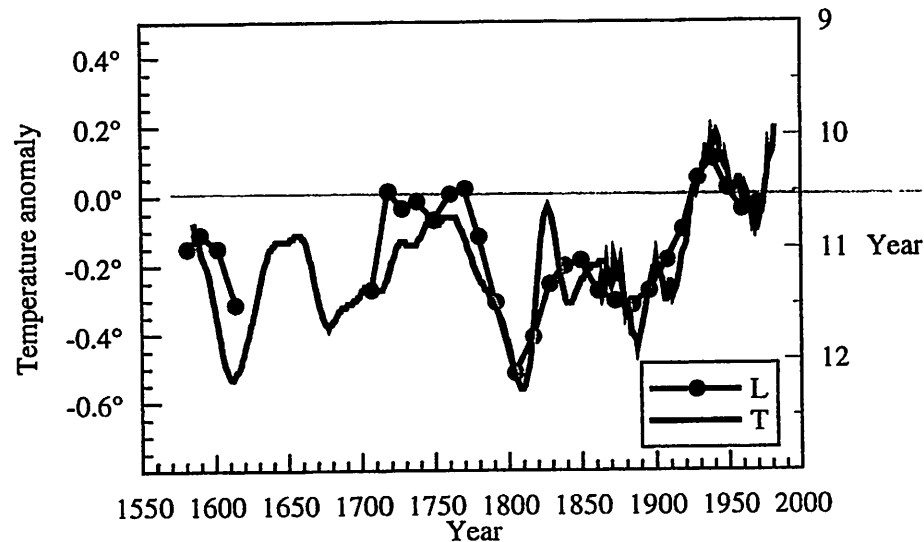

- Global temperature T
  - 11-y running average of Northern Hem. land temperature, before 1860 estimated by means of tree-ring analyses.
- Long-term variation of solar activity
  - length of the sunspot or auroral (before 1850) cycle L

*Basic interaction channels between the principal domains of the STR system: Sun and solar wind (red), magnetosphere and ionosphere (blue), middle atmosphere (green), and troposphere and Earth (black).*

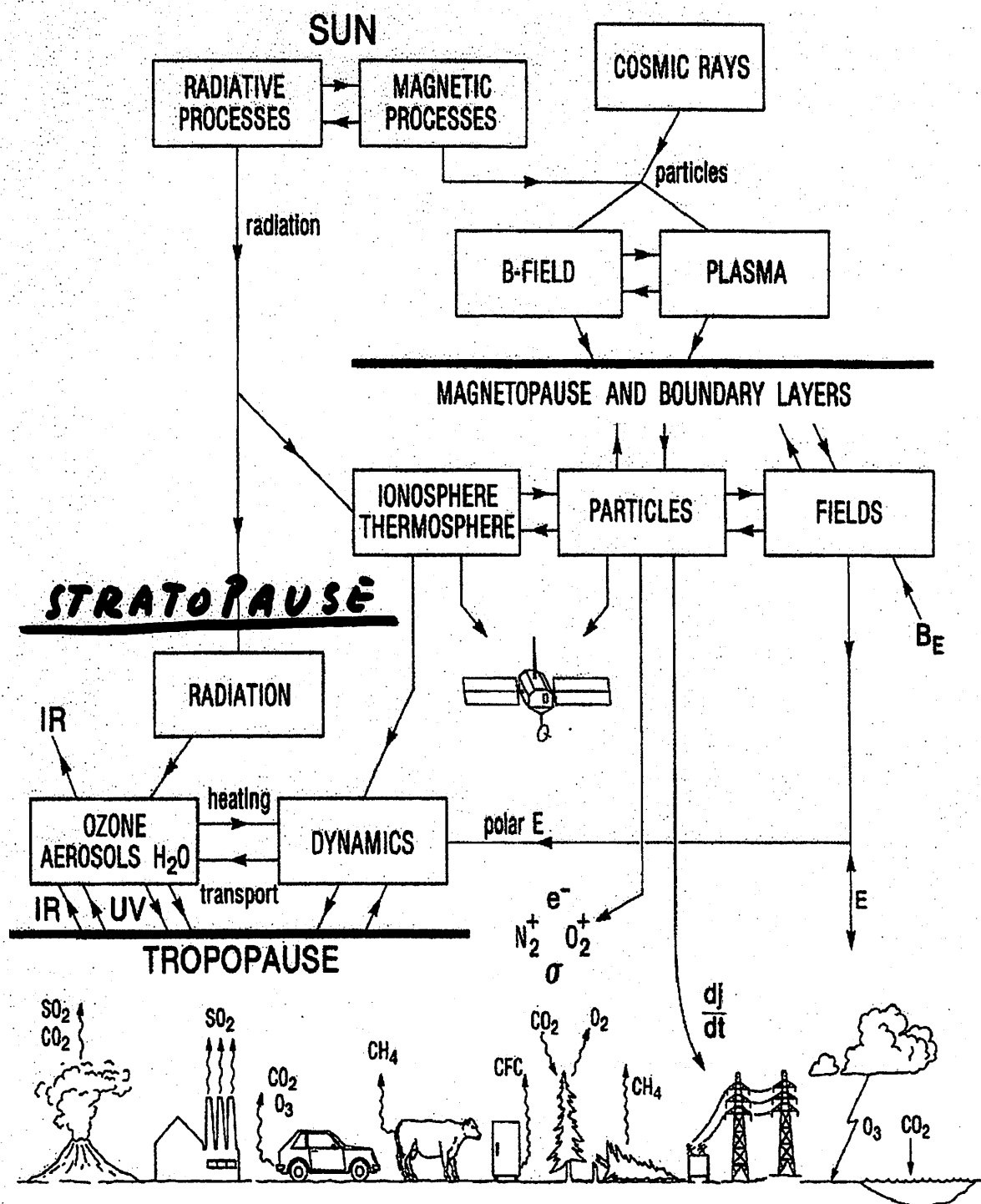

## **Solar Variability and Climate: Suggested Mechanisms**

- **Variations in spectral irradiance in the ultraviolet**
  - **Changes in stratospheric temperature and winds**
  - **Changes in planetary wave propagation**
  - **Changes in tropospheric dynamics**
  
- **Variations in total irradiance (the solar “constant”)**
  - **Changes in the earth’s radiation budget**
  - **Regional and global climate change**
  
- **Variations in the solar wind**
  - **Varying cosmic-ray fluxes**
  - **Changes in the global electric circuit**
  - **Modification of global cloudiness**

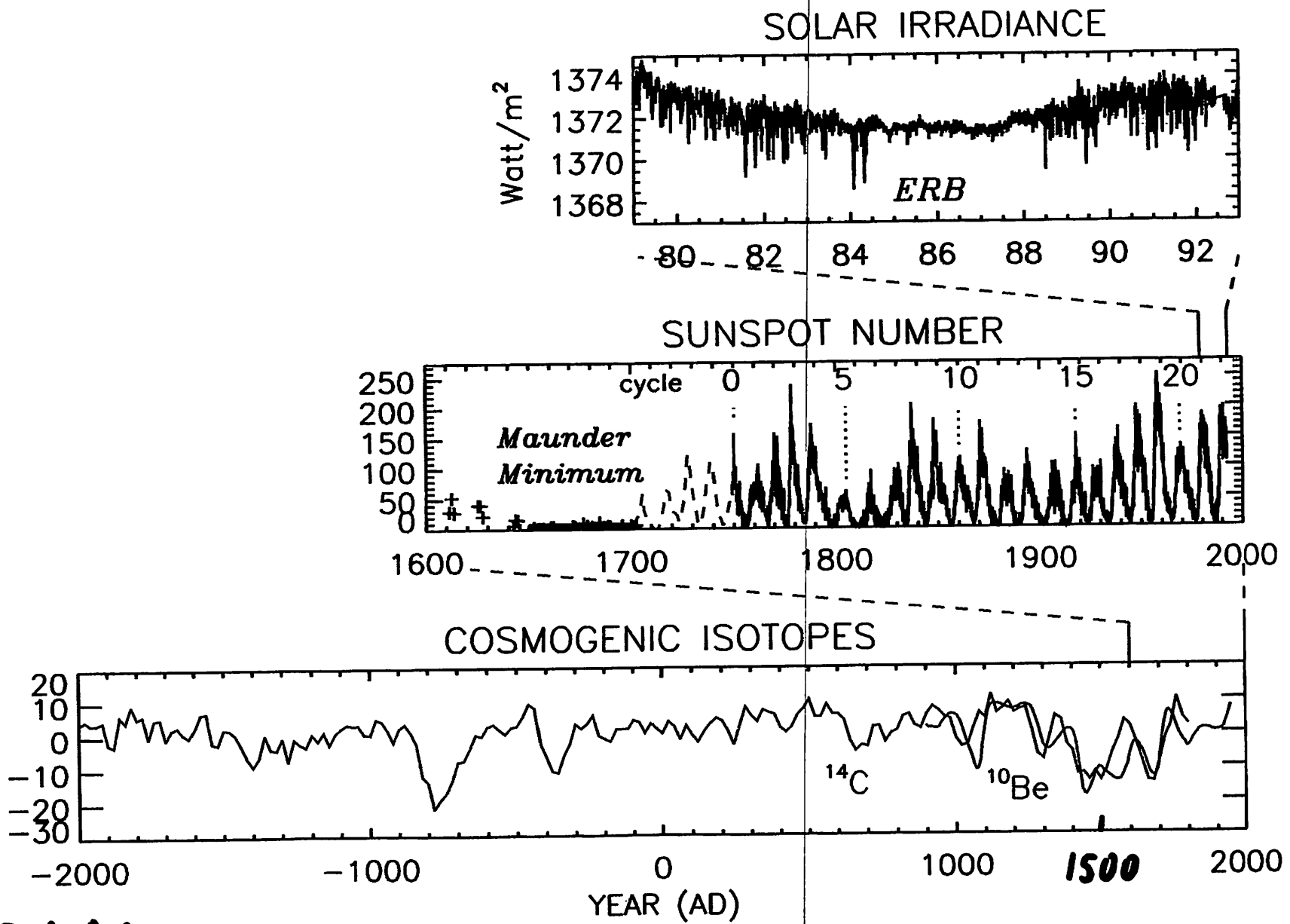

J. LEAN

SHORT TERM. DIRECT INDICES OF SOLAR VARIABILITY

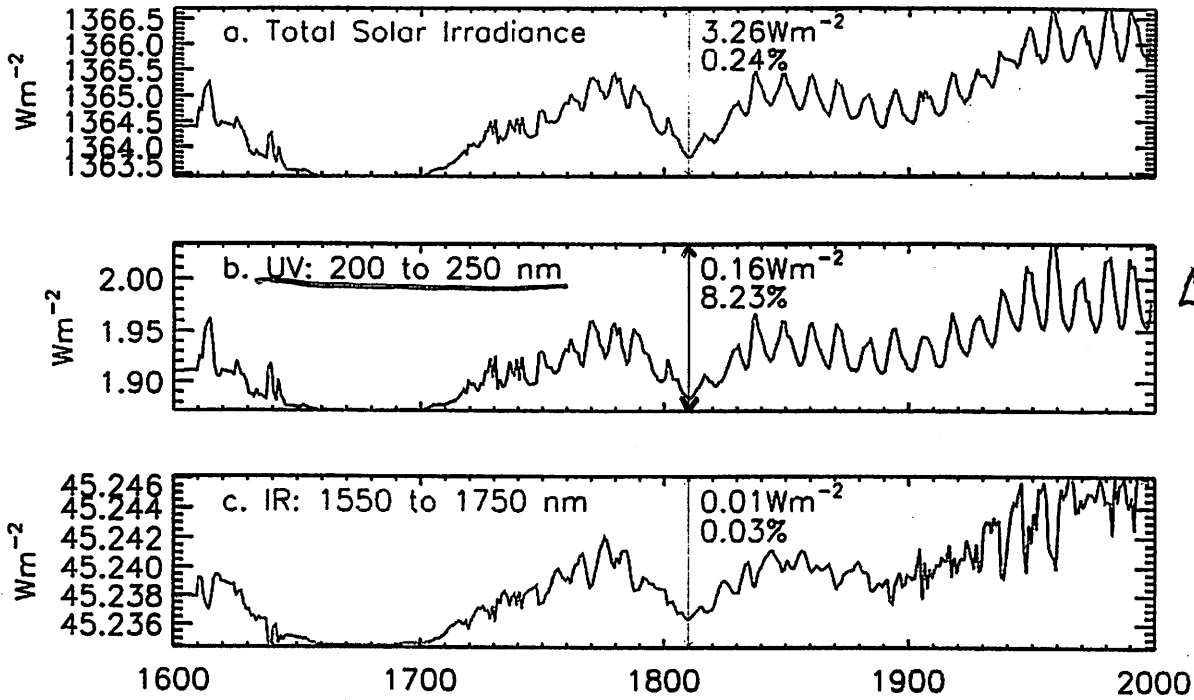
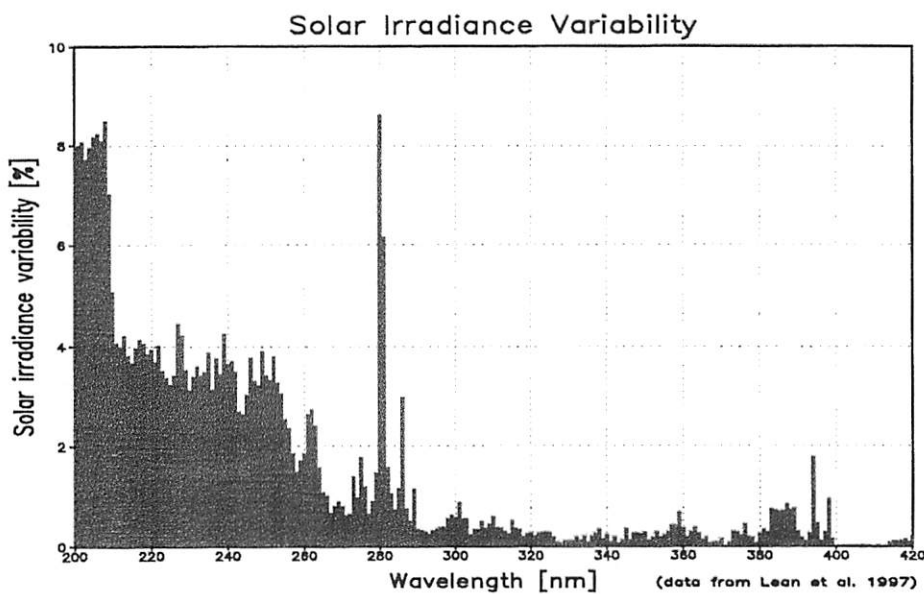
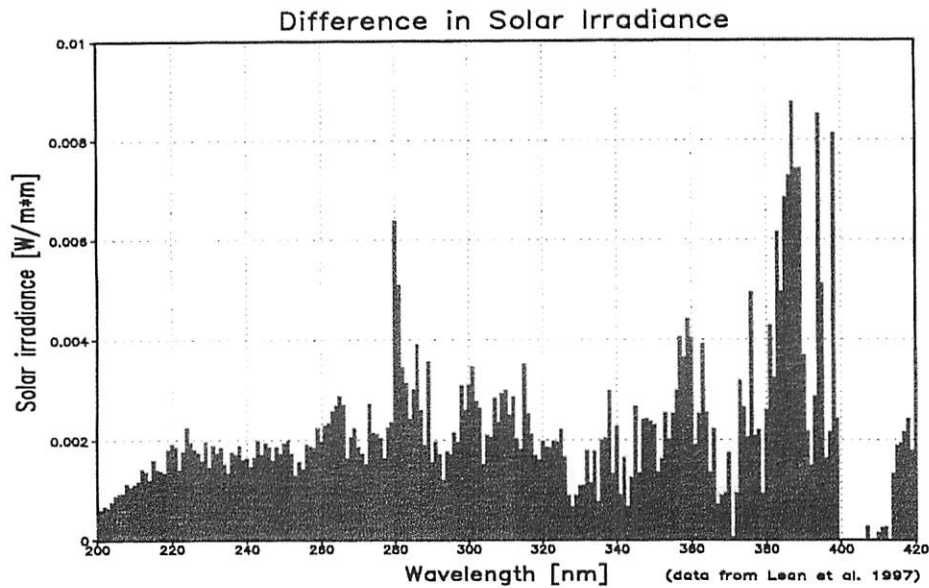

Figure 9. Model estimates of long-term variability in the total solar irradiance and in two spectral bands in the UV and IR. In these calculations, the adopted amplitude of the long-term facular component is approximately equal to its contemporary solar cycle amplitude.

# Variability of the Solar Irradiance between Solar Maximum and Solar Minimum in the Ultra Violet (200-420nm)



**The SUN has an influence on the stratosphere through more UV radiation during solar maximum than during the minimum.**

**This leads to more ozone and this couples back to the troposphere and to our climate.**

# Temperature Differences between Solar Maximum and Solar Minimum (K)

T max-min (K) annual mean 20y

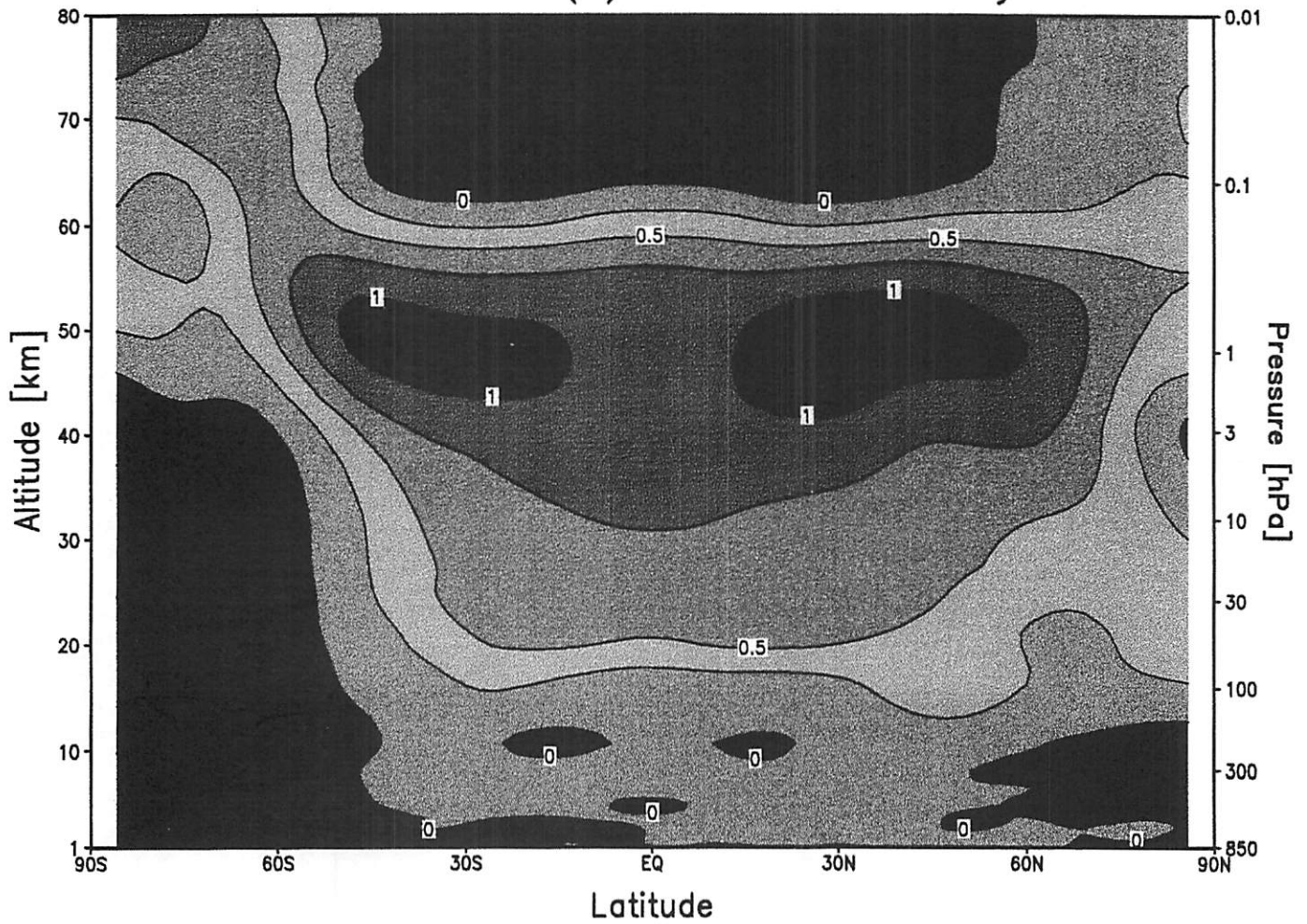



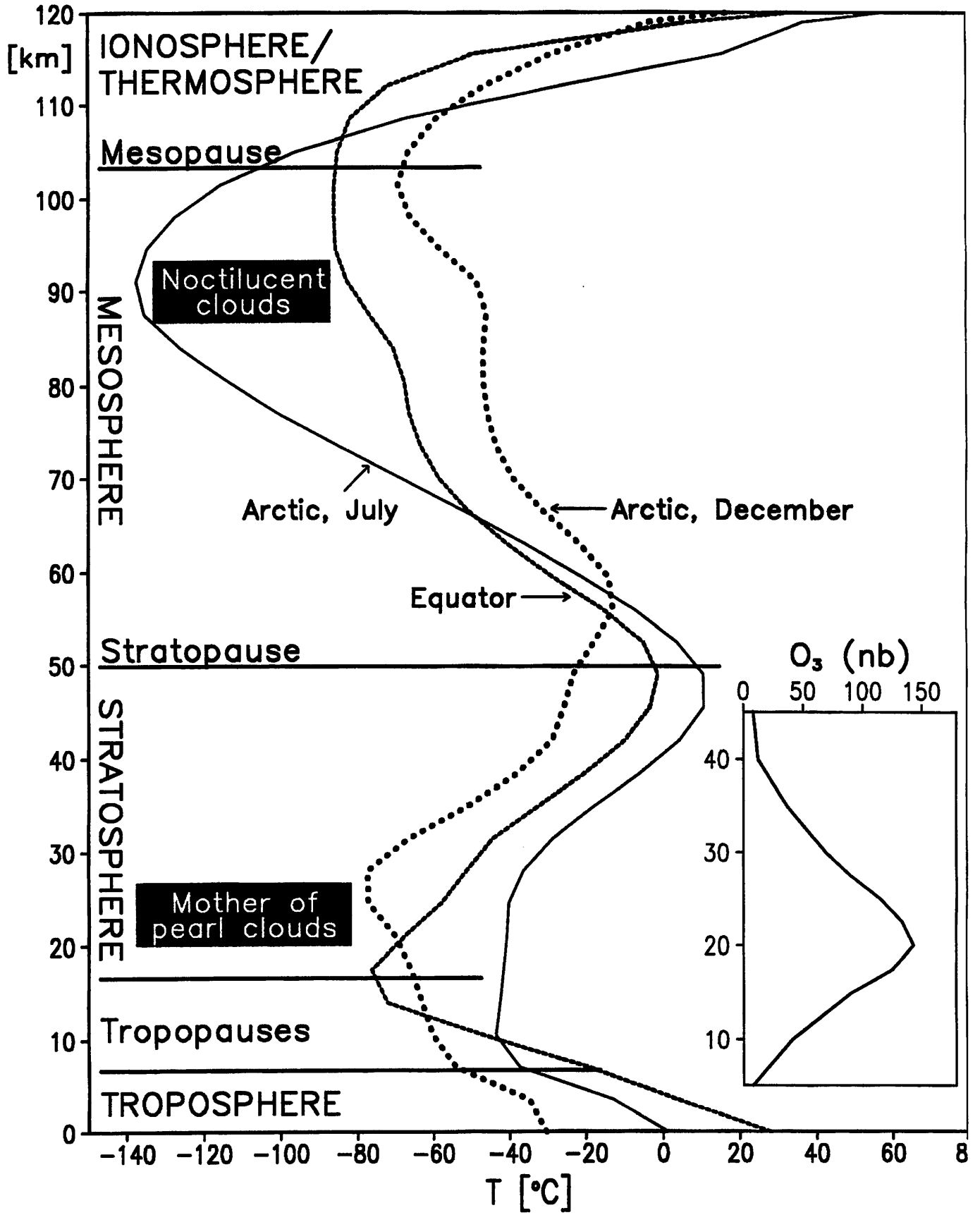

### Detrended Annual Mean 1968–2000 NCEP/NCAR

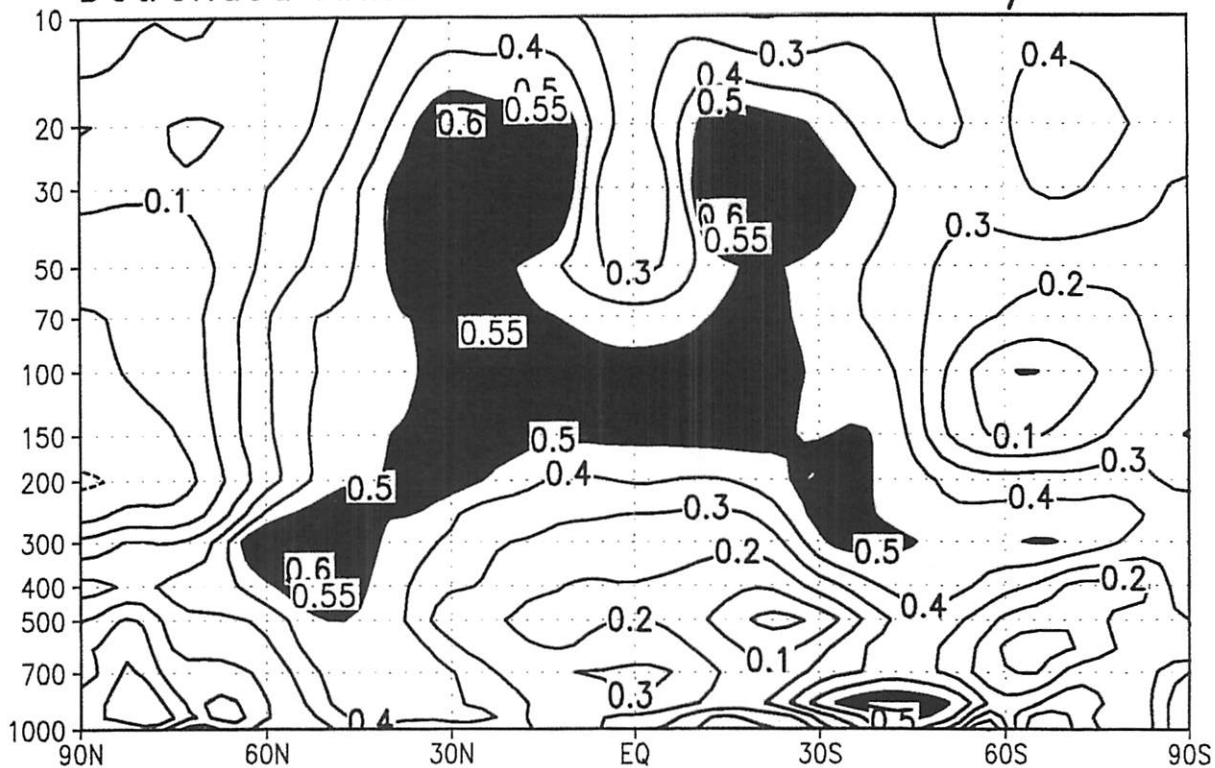

r(Solar Cycle; Temp)

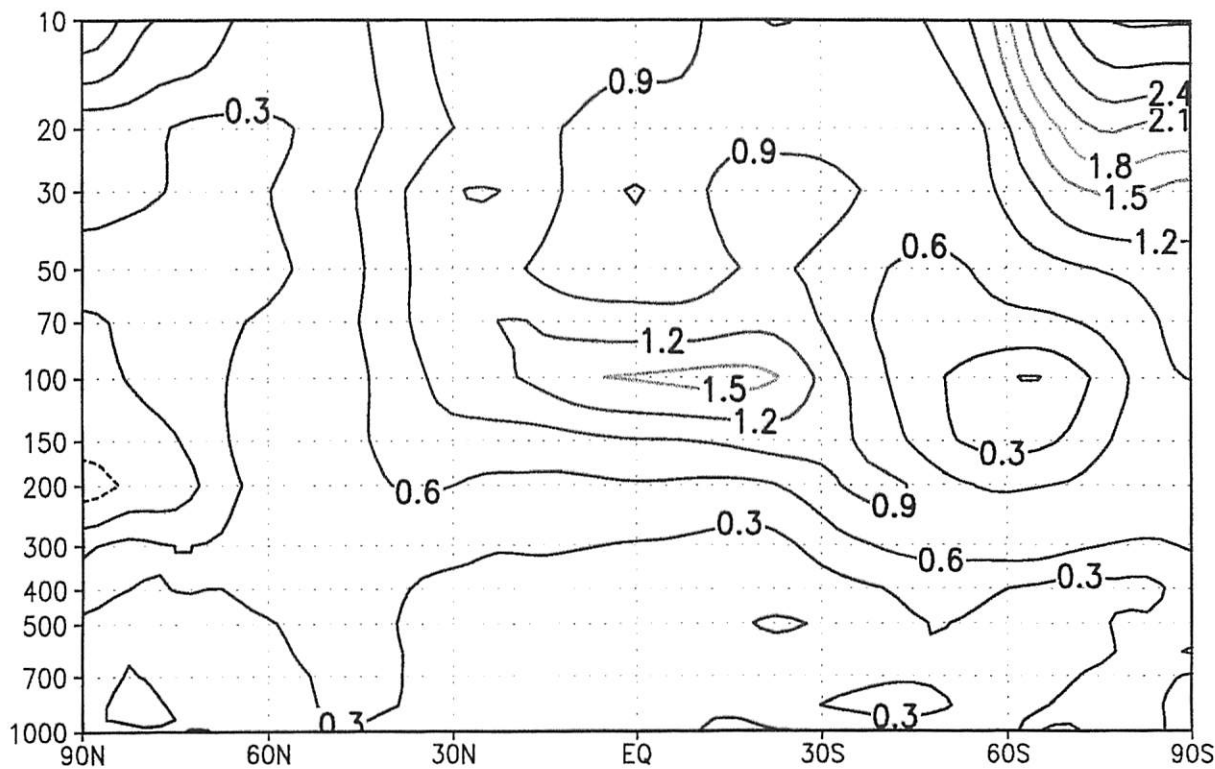

Temperature Diff [K]

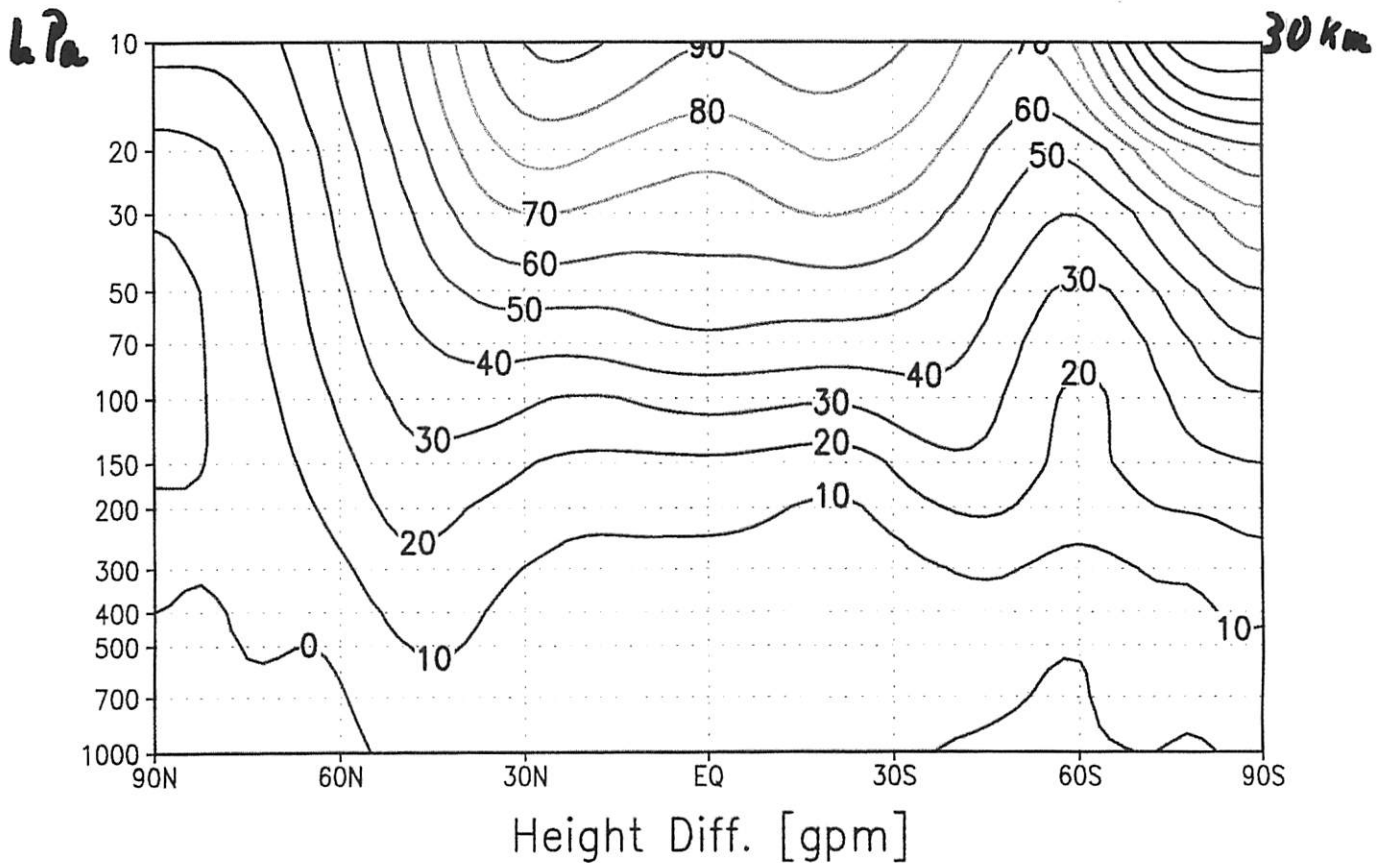
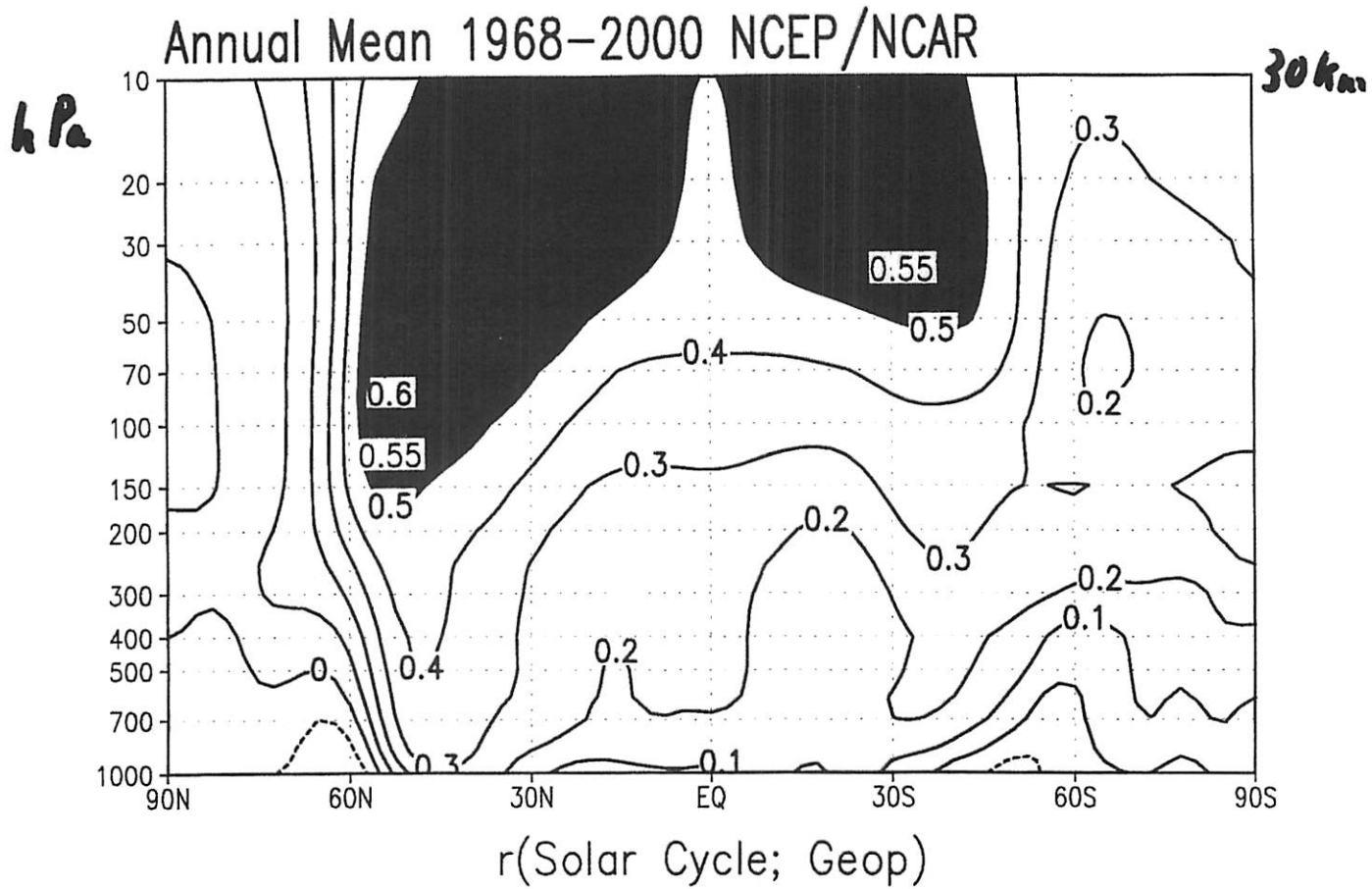

# Detr. Annual 100 hPa Temp. 1968-2000 NCEP/NCAR

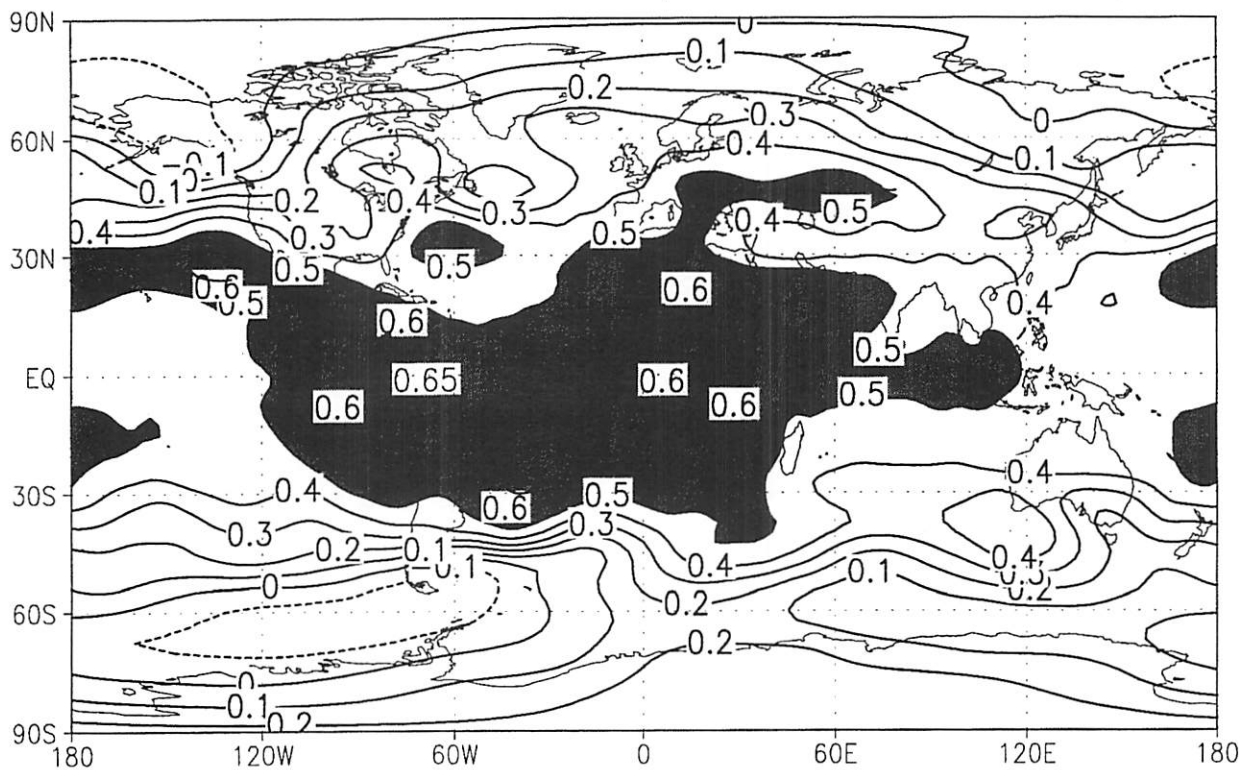

$r(\text{Solar Cycle})$   $n=33$   $\text{min}=-0.17$   $\text{max}=0.73$

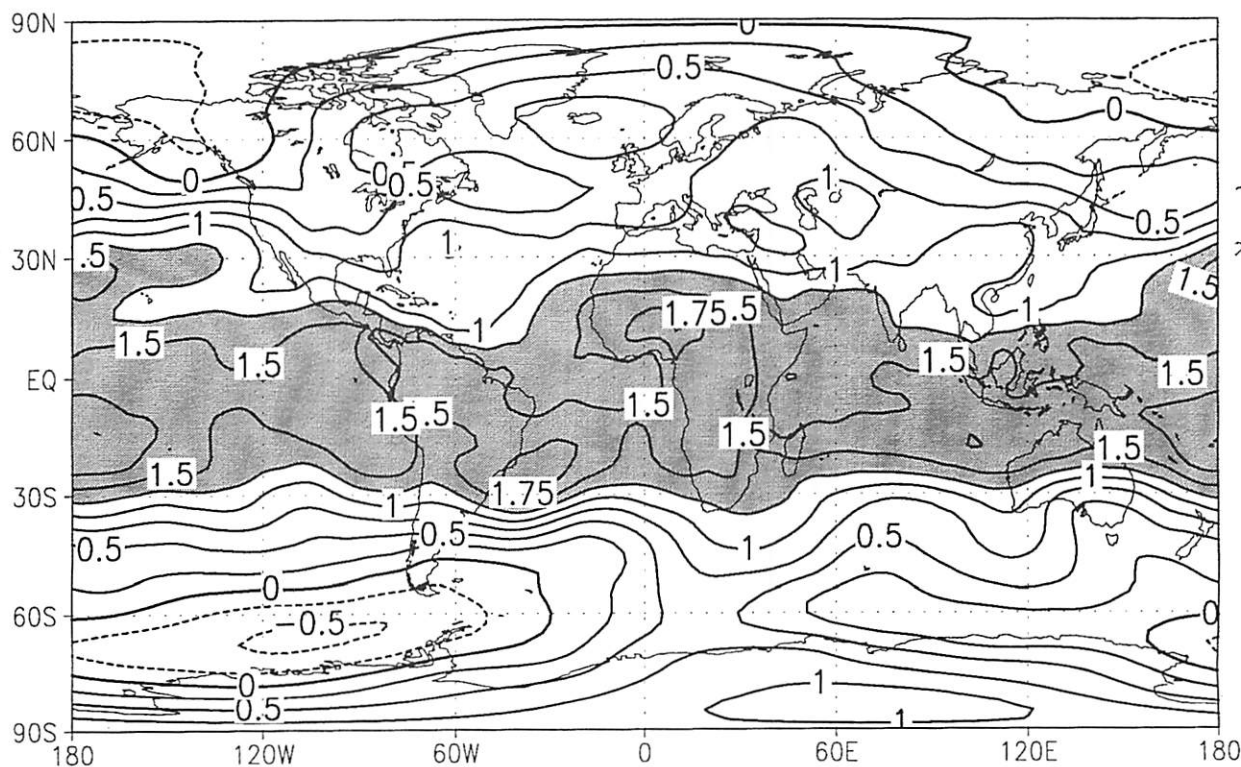

$> 1.25^\circ$   
shaded

Temperature Diff. [K]

# Annual Mean 30H 1968-2000 NCEP/NCAR

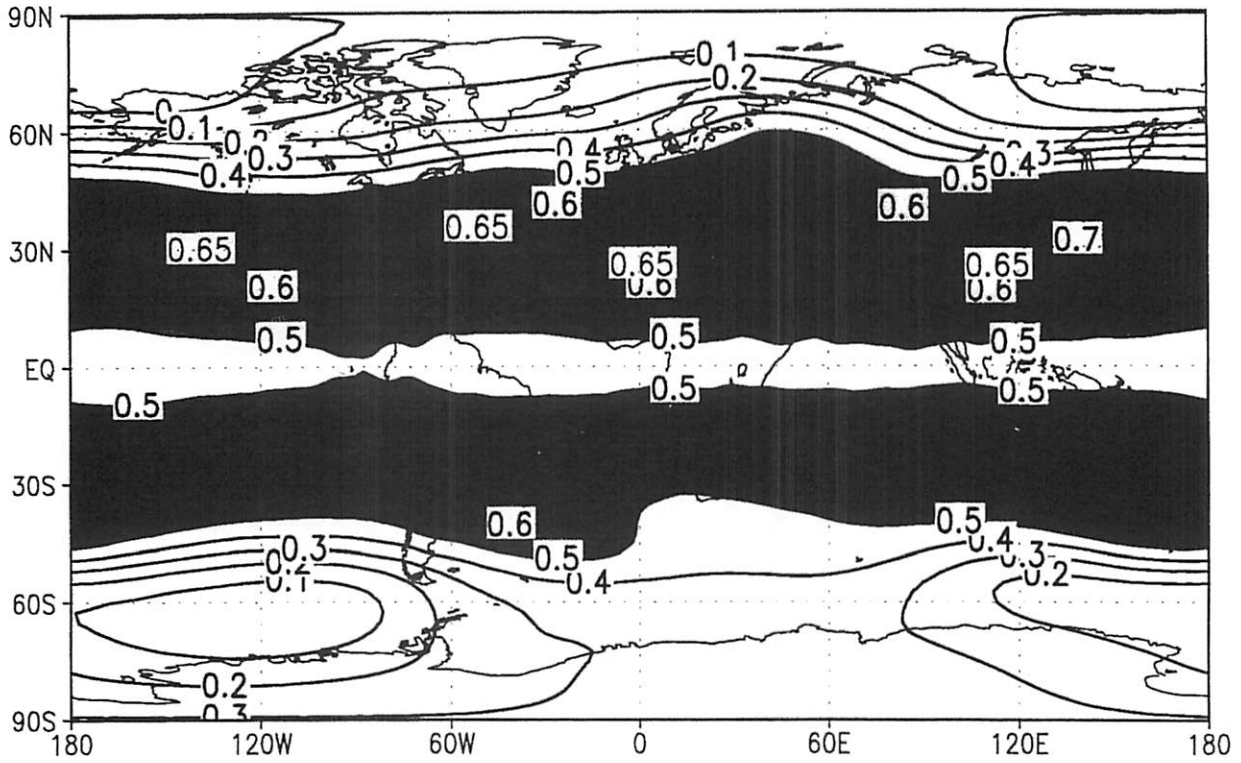

$r(\text{Solar Cycle})$   $n=33$   $\text{min}=-0.07$   $\text{max}=0.71$

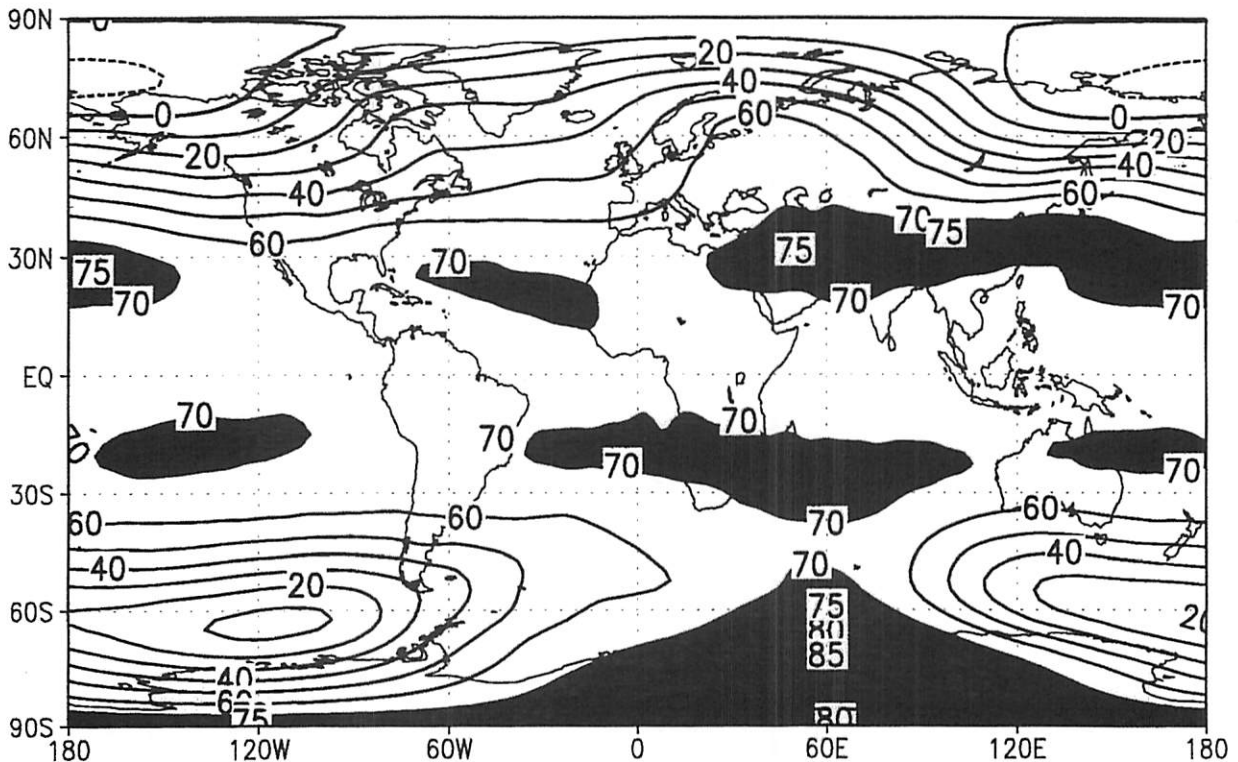

Height Diff. [gpm]

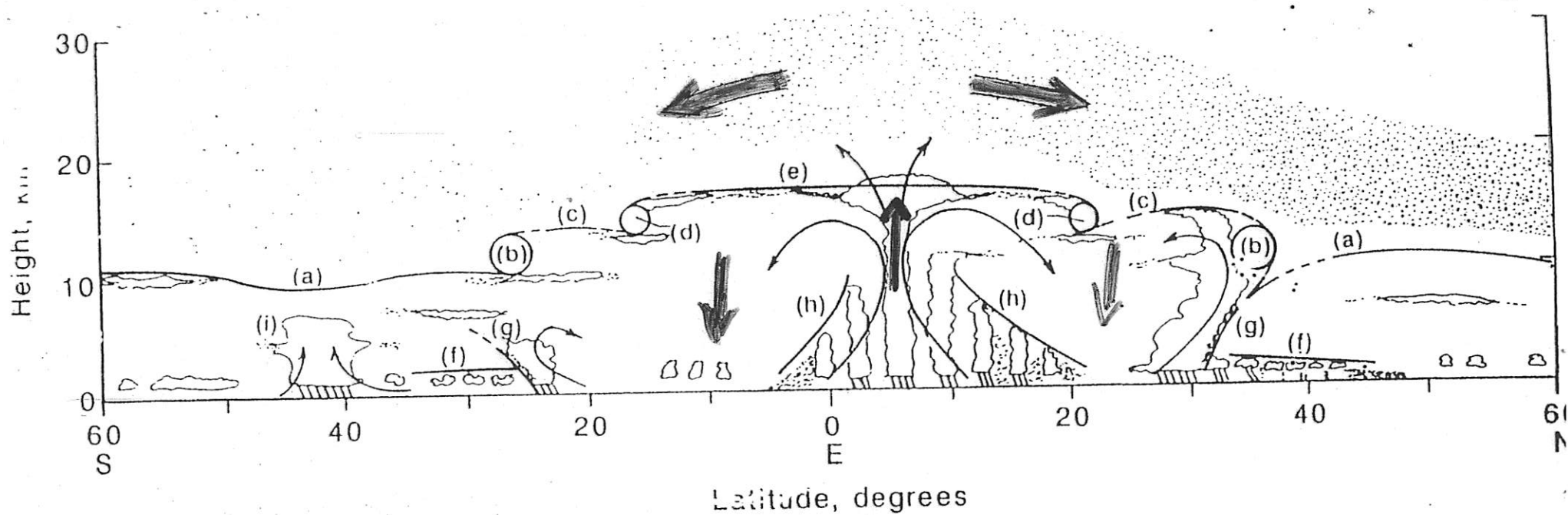
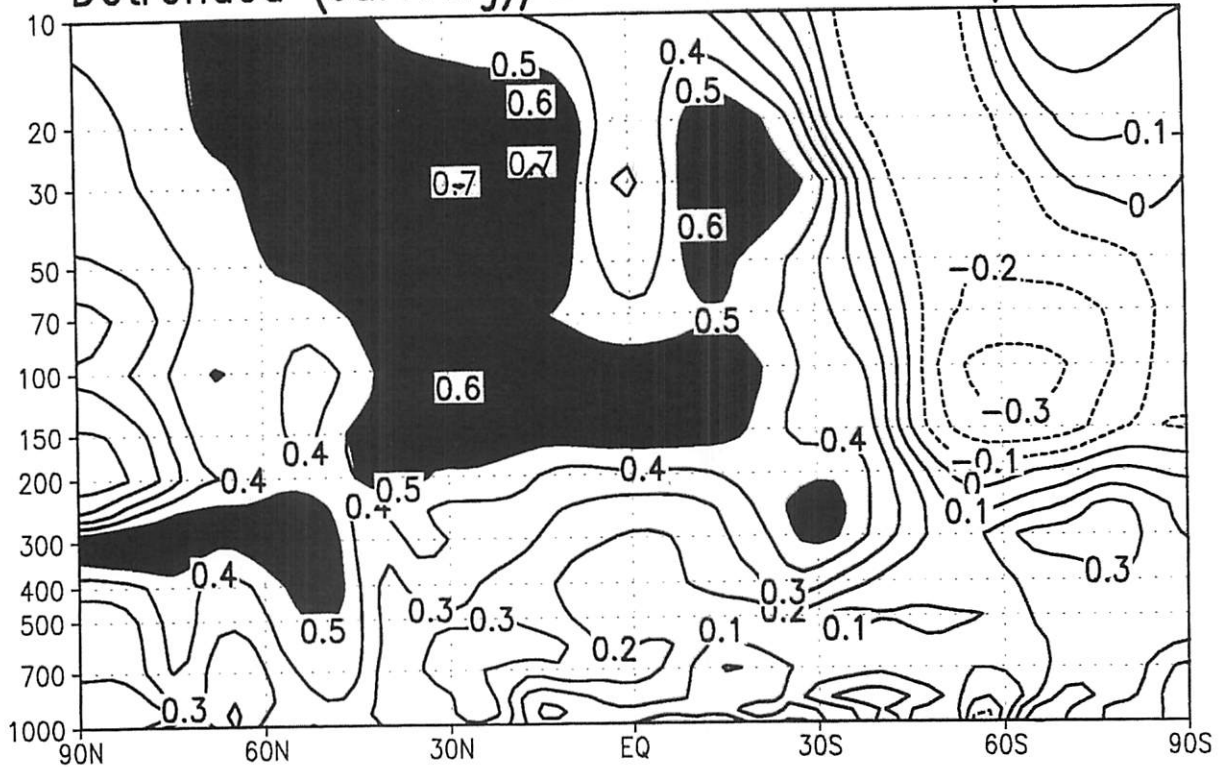

FIG. 4. Latitudinal cross section of the atmosphere depicting the locations of the (a) polar tropopause; (b) pola. jet; (c) subtropical tropopause; (d) subtropical jet; (e) tropical tropopause; (f) convective PBL; (g) frontal systems; (h) trade inversion; and (i) midlatitude storm

McCormick et al.  
1993 (BAMS)

### Detrended (Jul+Aug)/2 1968-2000 NCEP/NCAR



$r(\text{Solar Cycle; Temp})$

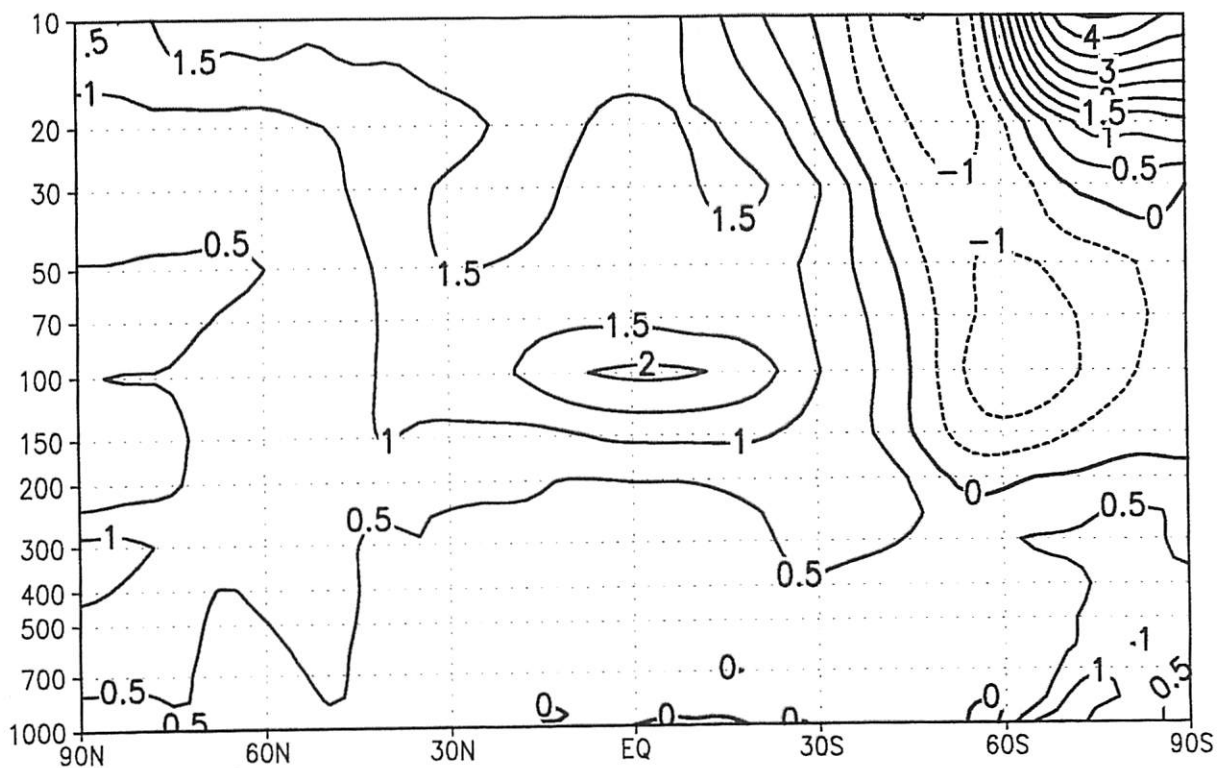

Temperature Diff [K]

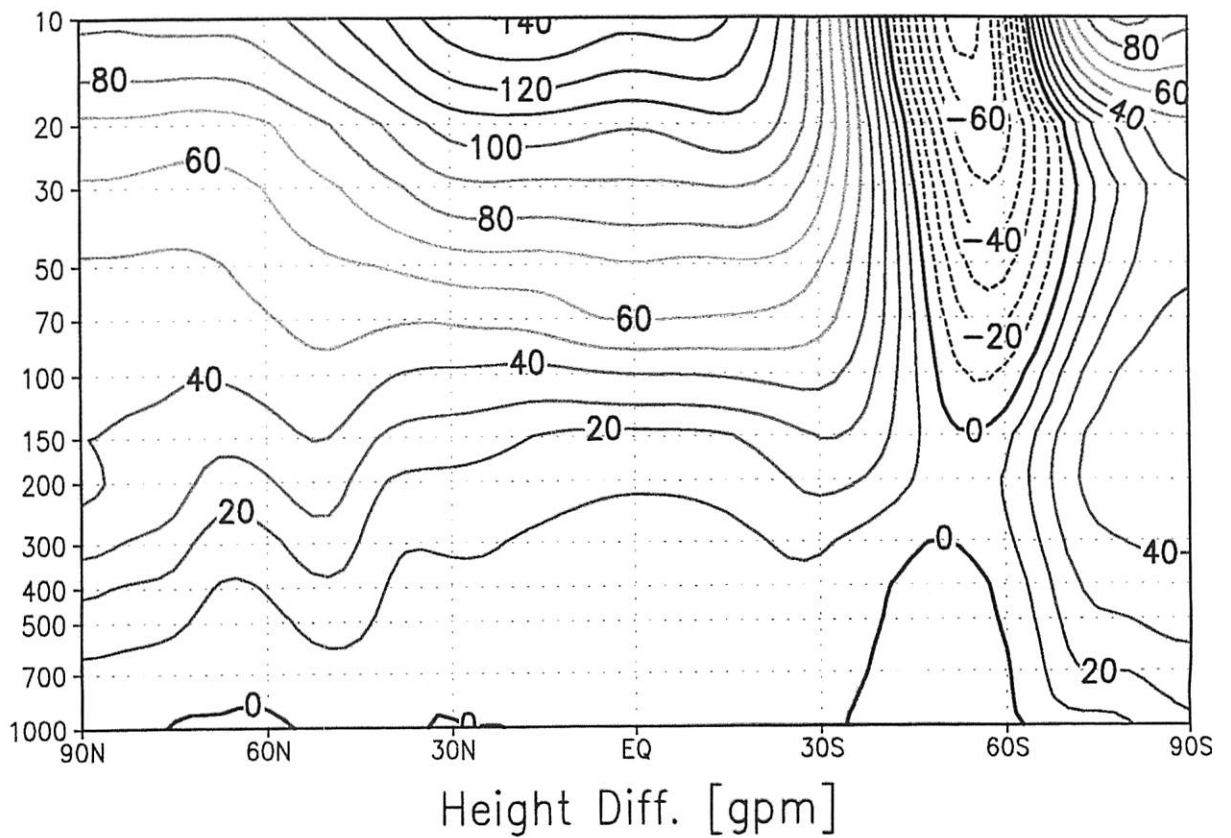
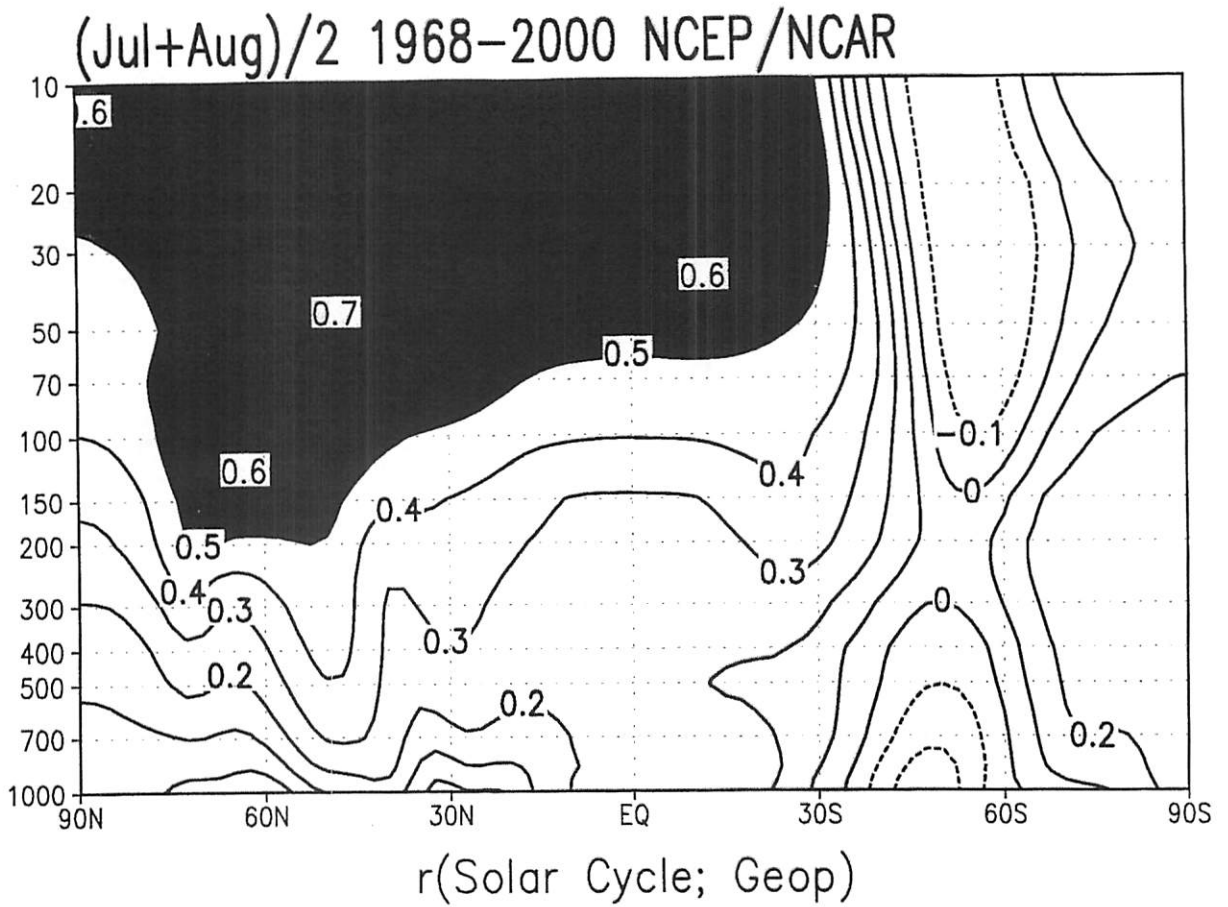



# Solar Cycle; 30hPa Height (Jul+Aug)/2 1968-2000 NCEP/NCAR

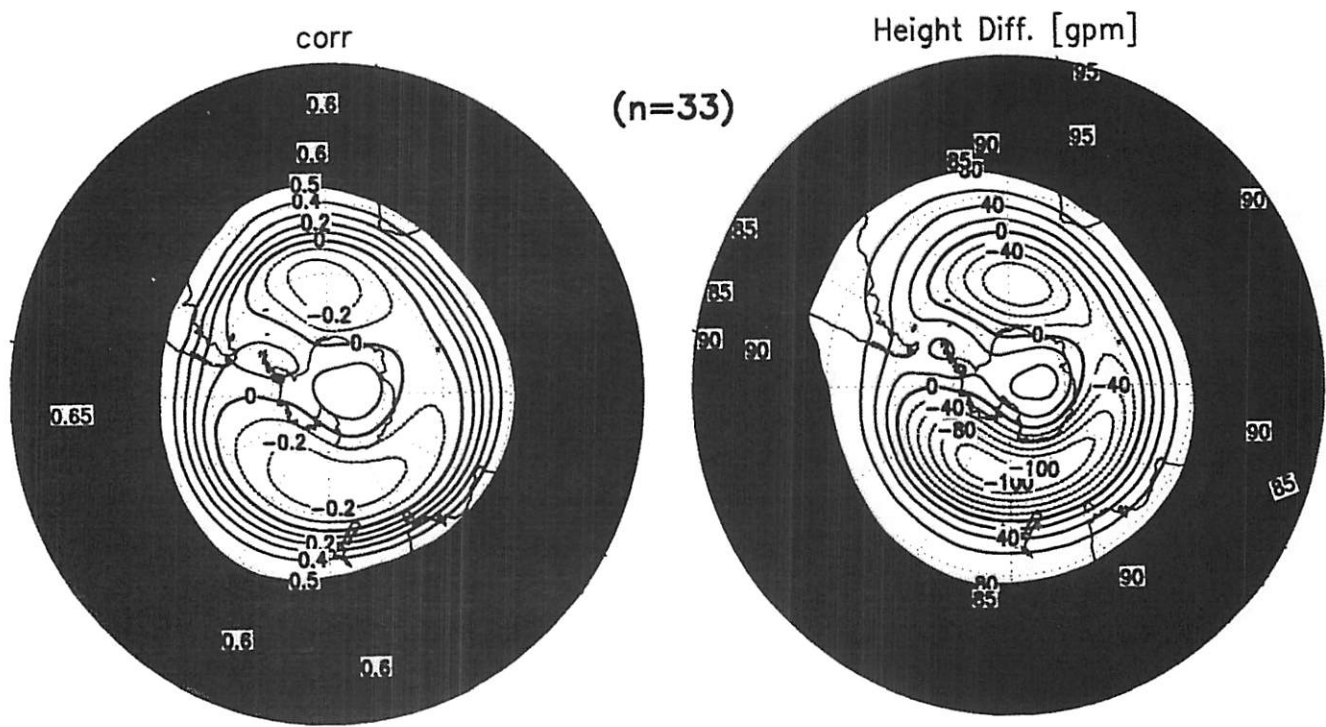
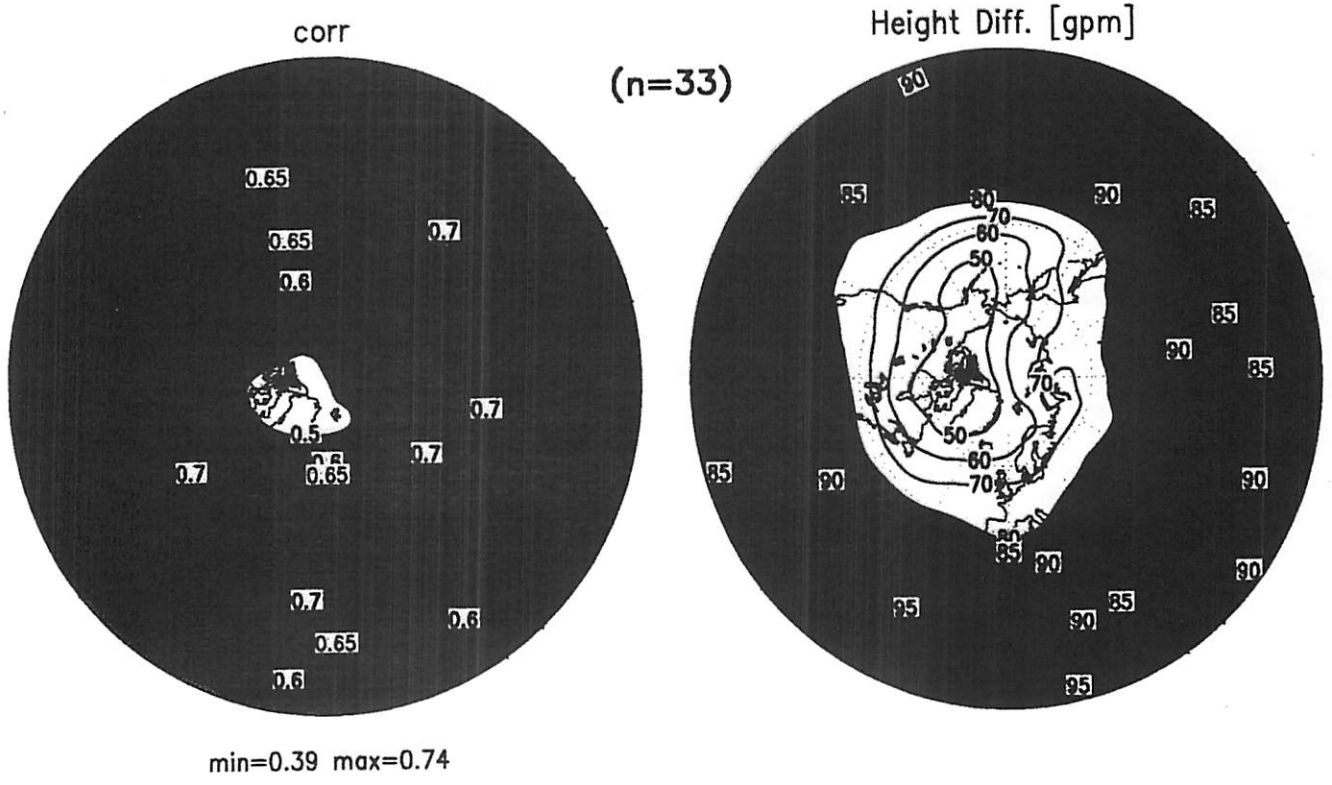

(Jul+Aug)/2 (3yr running) 30hPa-Height

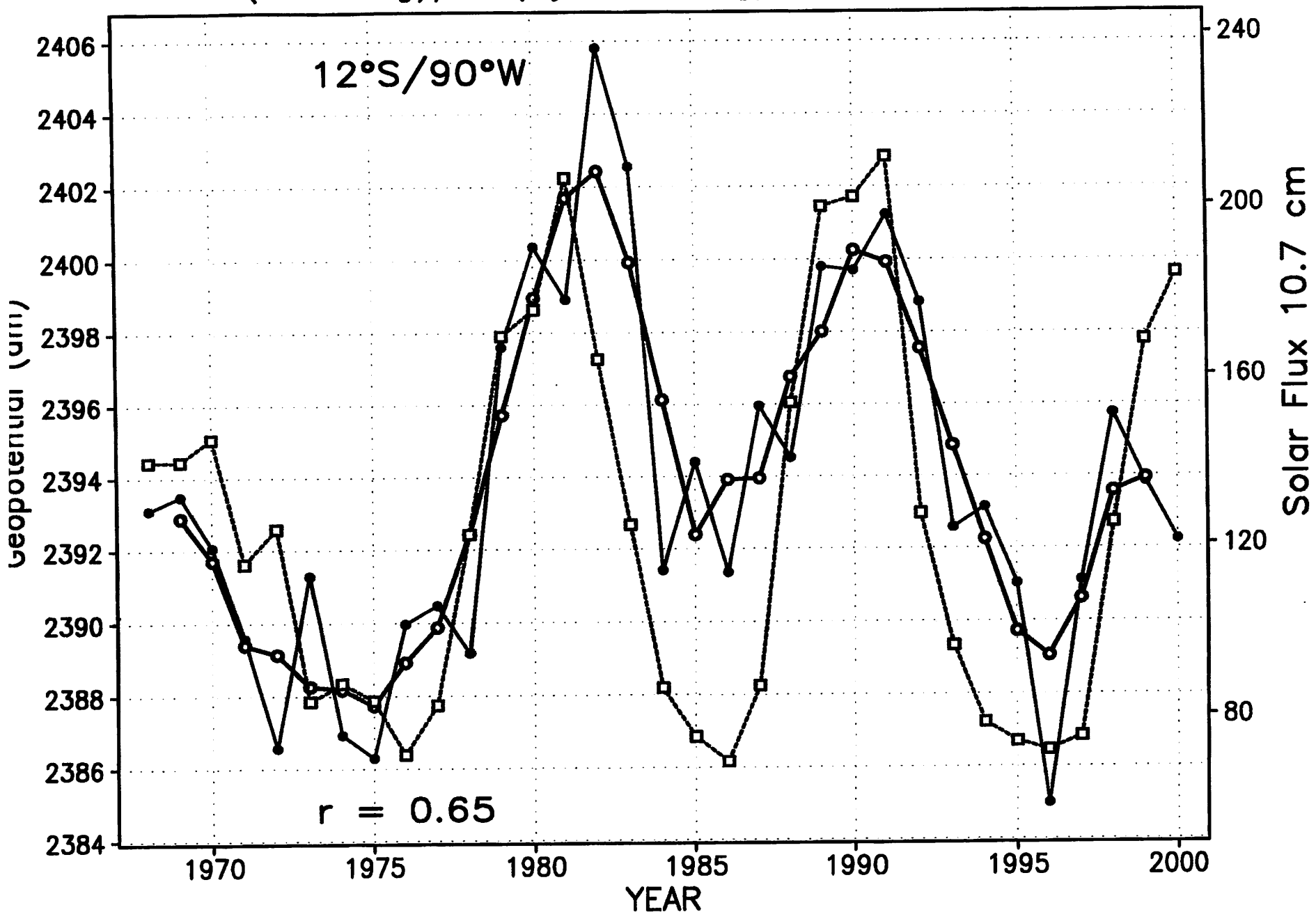

# Detr. Temp Differences (Jul+Aug)/2 NCEP/NCAR 1968-2000

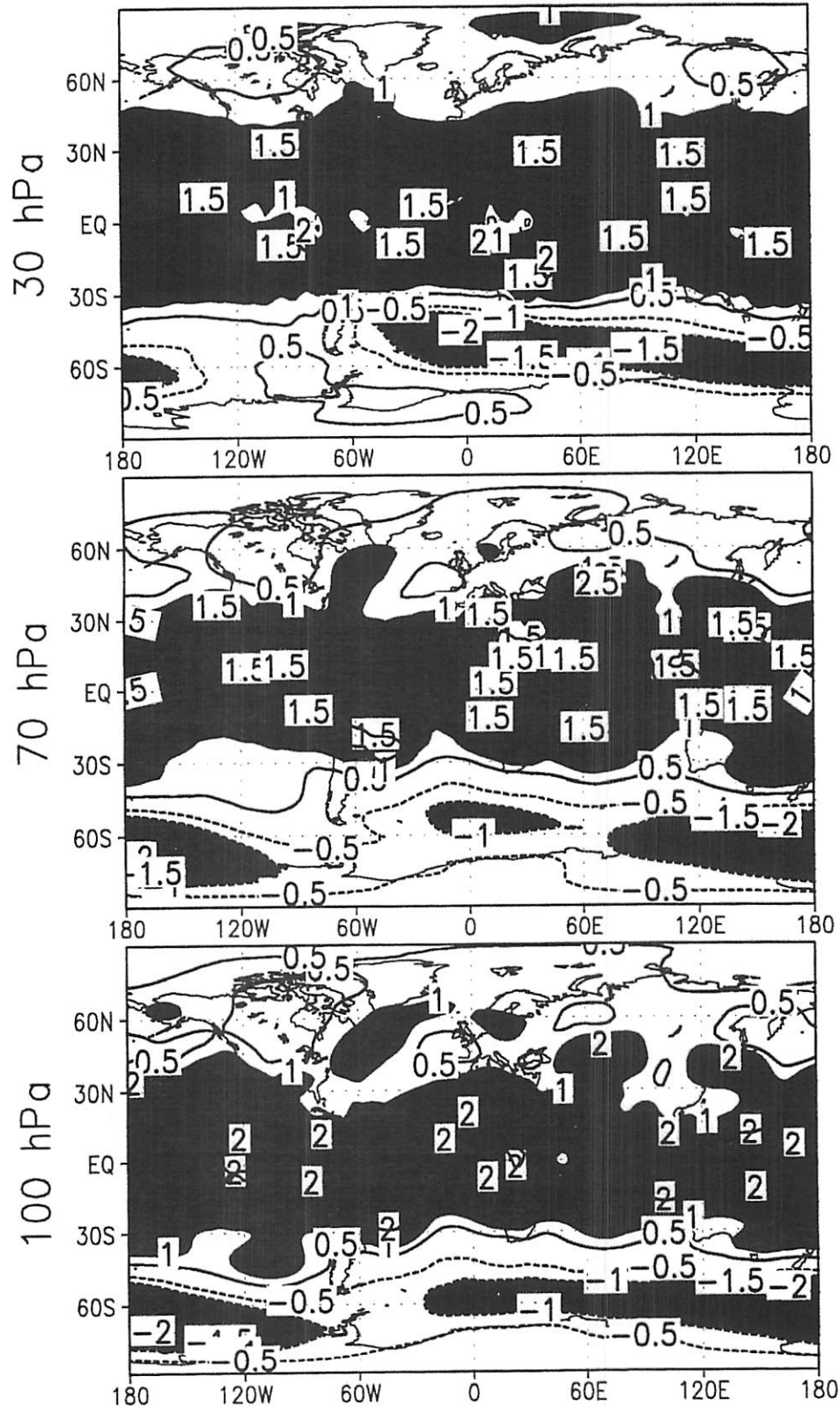

# r(Solar Cycle;30hPa Height) NCEP/NCAR 1968-2000

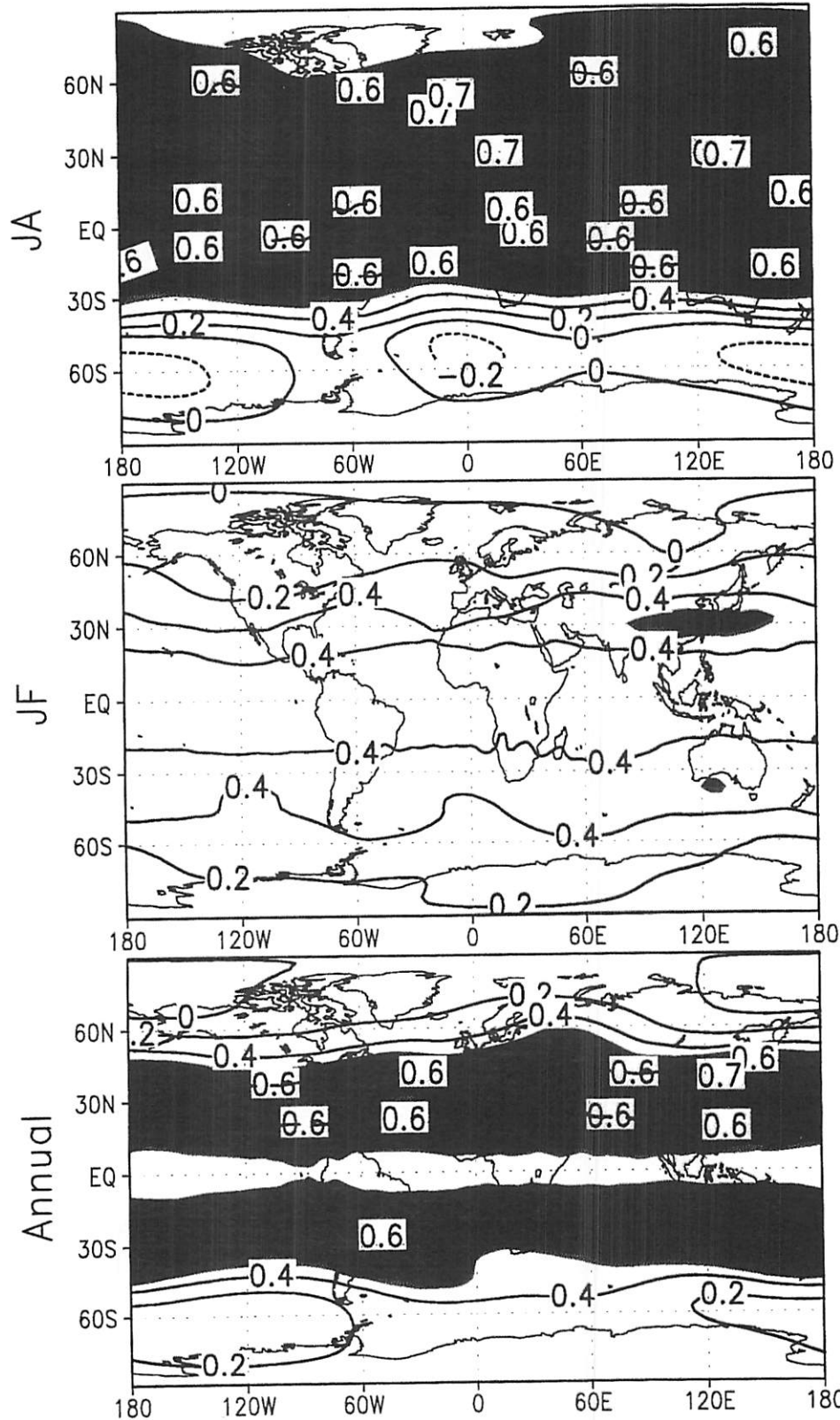

## CONCLUSION

- **Reconstruction of historical solar constant data and comparison with historical temperature records indicate a possible link between changes of the total solar irradiance and changes of the global temperatures.**  
Until 1800, the statistical studies imply a predominant solar influence on the climate; extending the studies to the present suggests that solar forcing may have contributed about half of the observed 0.55K surface warming since 1860, and one third of the warming since 1970.
- **Calculations of the magnitude of the solar signal on the time-scale of 11-years show that over a large vertical and latitudinal range the Heights and temperatures are higher during solar maxima than during solar minima.**
- **We suggest that the solar effect influences the diabatic meridional circulation, and particularly the Hadley circulation in the sense that the solar signal intensifies the Hadley circulation**